

NOTE:
 ORDER ALL RedHeader PRO™ HEADERS
 1/2" LESS THAN ROUGH OPENING WIDTH
 TO FIT INSIDE HDSC HEADER BRACKETS.

RedHeader PRO.
 MEMBER SIZE AS
 REQ'D PER DESIGN.

FULL HEIGHT RedHeader PRO
 JAMB STUD.
 MEMBER SIZE AS REQ'D
 PER DESIGN.

(1) #10-16 SCREW
 TYP. EACH FLANGE

NOTE:

362 = 3-1/2" LONG
 400 = 3-7/8" LONG
 600 = 5-7/8" LONG
 800 = 7-7/8" LONG
 306 = 3-1/16" DEEP
 356 = 3-9/16" DEEP
 MILS: -33, -68, -97

RedHeader PRO HEADER
 BRACKET. MEMBER SIZE AS
 REQ'D PER DESIGN. WITH (4)
 #10-16 SCREWS TO HEAD AND
 (4) #10-16 SCREWS TO JAMB

ATTACH TRACK TO
 HEADER STUD USING:
 (2) #10-16 SCREWS
 @ 24" O.C.

CRIPPLE STUDS
 ABOVE OPENING

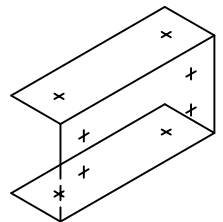
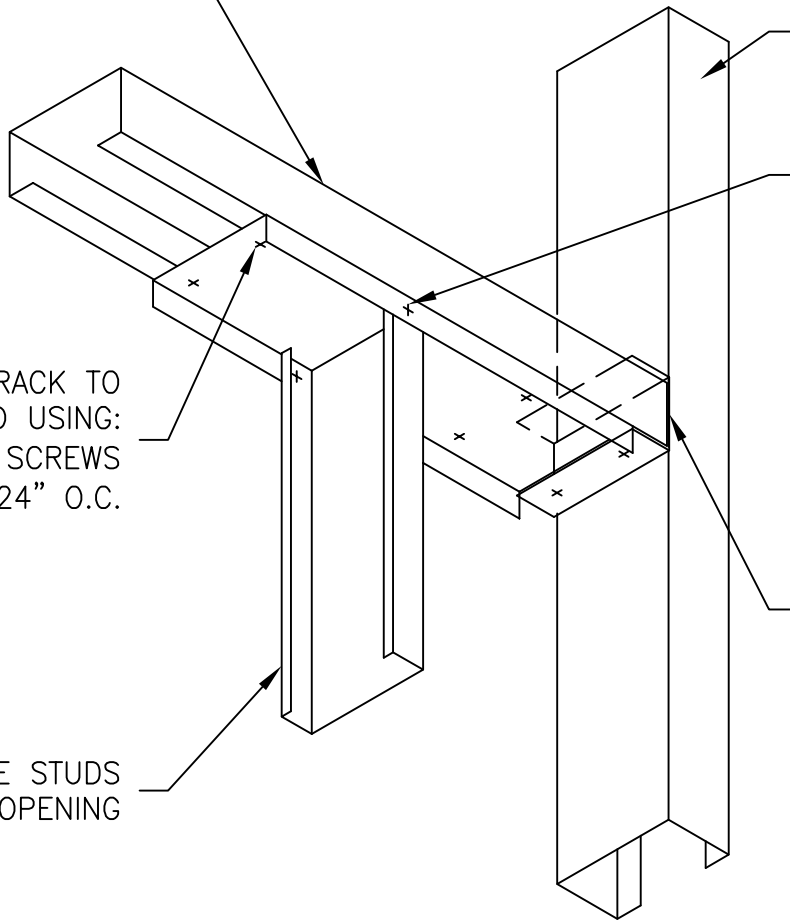

BAILEY®
 METAL PRODUCTS LIMITED

RedHeader SILL CONNECTION

CURTAIN WALL 3" or 3-1/2" FLANGE SILL USING:
 (1) RedHeader PRO STUD w/(1) TRACK

This detail library is intended to provide general framing details only and does not replace the judgments and designs of a qualified architect and/or engineer. The details are provided as a starting tool to assist the user in creating and detailing cold-formed steel framing construction details.

Each detail including accompanying text must be thoroughly evaluated and approved by a qualified architect or engineer.

© Copyright 2017 ClarkDietrich Building Systems For more information visit www.bmp-group.com or call (905) 738-9267