



THE STRENGTH WITHIN

# COMSLAB®

LONG SPAN COMPOSITE FLOOR SYSTEM



MONTREAL • TORONTO • CALGARY • EDMONTON • VANCOUVER

**BAILEY**®  
METAL PRODUCTS LIMITED





## ComSlab® COMPOSITE FLOOR SYSTEM

Proven, reliable and cost-effective

### ComSlab® COMPOSITE FLOOR SYSTEM

The ComSlab® System from Bailey is a two hour fire rated, structurally superior composite floor. It's specially designed for use in hotels, multi story residential buildings, long-term care facilities, multi family residential units, schools and/or office buildings. ComSlab® will accommodate all wall systems, including lightweight steel framing, structural steel, masonry or poured concrete, insulated concrete forms or wood framing construction. It is a proven, reliable, and cost-effective composite steel deck installed in almost 1000 buildings to date.

A quality product, manufactured by Bailey Metal Products Limited, ComSlab® is lightweight and self-seating for long-span flooring requirements. Easy to work with, it can be rapidly installed in even the tightest work environments. It's a practical solution, especially when building in, and around, tight downtown locations where large truck access is limited.

The ComSlab® System is designed for applications and use in all building construction. Its unique concept allows for flexible design options. It easily accommodates the placement of all services, duct work and conduit. ComSlab® sections can be supplied pre-cut to your specifications for even greater time and material savings.

ComSlab® is best used in facilities where fire rating is paramount and it can be adapted to many other environmentally friendly building opportunities. It's an economical and creative option for the construction of mezzanines, dry-deck roofing and roof-top green spaces or gardens.

**ComSlab® IS A LEED FRIENDLY PRODUCT FOR RECYCLABILITY, WASTE REDUCTION AND CLEAN AIR BUILDING.**



## TABLE OF CONTENTS

Introduction.....	2
Benefits.....	4
Design Criteria and Technical Data.....	5
Construction and Installation Guidelines.....	6-8
Suggested Construction Details.....	9-11
Fire Resistance and Acoustical Performance.....	12
Round Service Hole Details.....	13
Maximum Round Service Hole Diameters.....	13
Concrete Volume Values for Estimating.....	13
Reinforcing Bar Information.....	13
Steel Deck and Accessories.....	14
Use of Deflection Parameter.....	15
Unshored Span Requirements - Metric & Imperial.....	15
Span Tables - Metric.....	16
Span Tables - Imperial.....	17
Design Data - Metric.....	18
Design Data - Imperial.....	19

### ComSlab® CROSS SECTION PROPERTIES

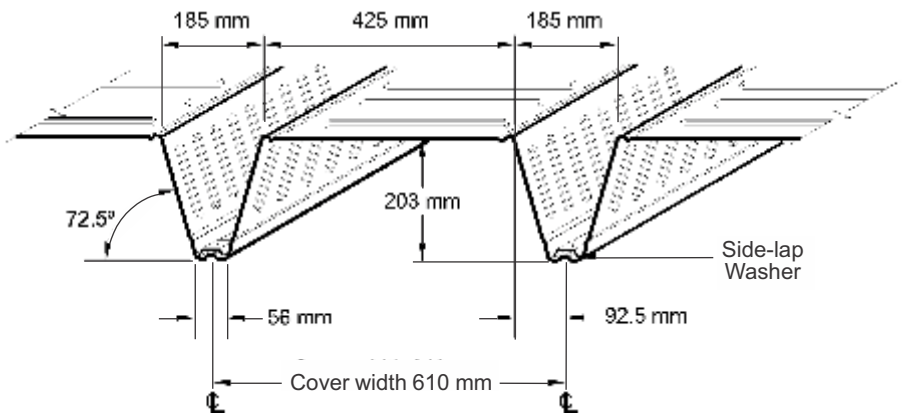

### IMPERIAL UNITS

Base Steel Thickness (in.)	Profile Depth (in.)	Profile Weight (psf)	$A_g^1$ (in. <sup>2</sup> /ft.)	$A_e^2$ (in. <sup>2</sup> /ft.)	$S_p^3$ (in. <sup>3</sup> /ft.)	$I_x^4$ (in. <sup>4</sup> /ft.)
0.0375	8.00	2.58	0.727	0.297	0.690	3.41
0.0495	8.00	3.41	0.960	0.444	1.287	5.62

### SI METRIC UNITS

Base Steel Thickness (mm)	Profile Depth (mm)	Profile Mass (kg/m <sup>2</sup> )	$A_g^1$ (mm <sup>2</sup> /m)	$A_e^2$ (mm <sup>2</sup> /m)	$S_p^3$ (10 <sup>3</sup> mm <sup>3</sup> /m)	$I_x^4$ (10 <sup>4</sup> mm <sup>4</sup> /m)
0.953	203	12.60	1539	628	37.00	4.65
1.257	203	16.60	2031	940	69.10	7.66

### TABLES NOTES

<sup>1</sup>  $A_g$  = Gross cross sectional area of profile per unit width.

<sup>2</sup>  $A_e$  = Effective cross sectional area of profile per unit width.

<sup>3</sup>  $S_p$  = Effective section modulus of profile per unit width for positive bending.

<sup>4</sup>  $I_x$  = Effective moment of inertia of profile per unit width.





# COMSLAB.



## ComSlab® COMPOSITE FLOOR SYSTEM

### WHY CHOOSE ComSlab® COMPOSITE FLOOR SYSTEM?

#### ComSlab® BENEFITS



##### Fast Track Construction

- Simple base components
- Permanent concrete form
- Instant working platform
- Minimal crane time
- Low obstruction line shoring allows fit-up to closely follow structural framing



##### Versatile

- Incorporates easily into any substructure: steel, concrete, masonry, ICF and framed wall systems



##### Sound Attenuation Performance

- Up to STC 61



##### Long Clear Spans

- Allows for open concept designs



##### Efficient Use of Materials

- 40% less concrete and rebar versus conventional concrete slabs



##### Fire Performance

- 1.0, 1.5 & 2.0 HR designs without the need for drywall membrane or fire proof spray

 Underwriters Laboratories  
Laboratoires des Assureurs

 Underwriters Laboratories



# COMSLAB.



## DESIGN CRITERIA AND TECHNICAL DATA

This catalogue provides technical & structural information for the ComSlab® composite concrete slab system. All calculations, whenever applicable, were based on CSA Standard S136 and CSSBI documents. Design span tables are also presented, as well as various construction applications to assist the designer in detailing common structural assemblies. Additional assistance regarding the ComSlab® Composite Floor System construction method may be obtained by contacting the Bailey Metal Products sales office in your area.

The structural span tables and technical information contained in this catalogue were prepared by Dr. R.M. Schuster, P.Eng., Dist. Professor Emeritus of Structural Engineering at the University of Waterloo.

### MATERIALS

- Steel deck meets the requirements of **ASTM A653** Standard Specification of Steel Sheet, Zinc-coated (Galvanized) by the Hot-dip Process, Structural (Physical) Quality. The guaranteed minimum yield strength is **345 MPa (50 ksi)** with a minimum zinc coating mass of **275 g/m<sup>2</sup> Z275 (G90)** total both sides. Steel deck base thickness is **0.953 mm (0.0375 in.)** or **1.26 mm (0.0495 in.)**.
- Reinforcing steel meets the requirements of **CSA G30.18-09**. Guaranteed minimum yield strength is **400 MPa (58.0 ksi)**. The clear distance of each reinforcing bar from the bottom of the steel deck is **40 mm (1.57 in.)**.
- Concrete has a minimum cylinder strength of **30 MPa (4.35 ksi)**, with a maximum aggregate size of **20 mm (0.75 in.)**. Normal density structural concrete is **2400 kg/m<sup>3</sup> (150 lb/ft<sup>3</sup>)**.

### LIMIT STATES DESIGN (LSD)

- **Strength** – Limit states design principles were used in the development of the structural span tables, i.e., the factored resistance under consideration,  **$\phi R \geq$  the effect of the factored loads**. This is in accordance with the National Building Code of Canada, 2010. The self weight of the steel deck and the concrete have already been included in the structural span tables.
- **Serviceability** – The span tables are based on L/360 Live load deflections.

### SECTION PROPERTIES OF STEEL DECK

All structural section properties of the steel deck were calculated in accordance with **CSA Standard S136-12** and substantiated with tests at the STaR testing laboratory in Cambridge, Ontario.

### SHORING DURING CONSTRUCTION

ComSlab® Unshored Span Requirements were established in accordance with **CSSBI 12M-15**, using the following strength and serviceability/deflection criteria:

### SHORING DURING CONSTRUCTION (continued)

- **Strength** – Calculations were based on the combined loads due to the wet concrete, the steel deck and certain construction live loads. Minimum construction live loads applied separately are:
  - 1) **1 kPa (21 psf)** uniform load, or  
**2 kPa (42 psf)** uniform load (in some jurisdictions)
  - 2) **2 kN/m (137 lb/ft)** transverse concentrated line load at the centre of the span.Figure 1 of CSSBI 12M-15 illustrates the loading conditions that must be investigated for flexure/bending moment and web crippling.
- **Serviceability** – Calculated deflections were based on the uniform dead load due to wet concrete and steel deck, and the maximum mid-span deflection was limited to **L/180 or 20 mm (0.79 in.)**, whichever is smaller.

### SPAN TABLES

The span tables provide the maximum recommended spans that were established in accordance with **CSSBI S3-08**. As specified, both strength and serviceability/deflection criteria were considered as follows:

- **Strength** – Since shear-bond is not a mode of failure, only flexure/bending was considered. In accordance with Table 4.1.5.9 of the **2010 NBCC**, a **9 kN (203 lb)** specified concentrated live load was included in the strength calculations.
- **Serviceability** – The calculated deflection was based on the specified superimposed uniform live load with a maximum deflection of **L/360**. The modular ratio for normal density concrete was taken as **10** and the deflection moment of inertia was taken as the average of the uncracked and cracked moment of inertia of the ComSlab® section. For deflection ratios other than **L/360**, see page 6 for example. As well, to determine the deflection due to the slab weight, also see page 6.

### STRUCTURAL TESTING

Since the ComSlab® composite slab system also has reinforcing steel in each rib, shear-bond is not a mode of failure. This was substantiated by tests carried out at the University of Salford, by Prof. D. O'Leary in 1993 and recently in 2016 at the STaR testing laboratory in Cambridge, Ontario.





# COMSLAB.



## CONSTRUCTION AND INSTALLATION GUIDELINES

### DECK INSTALLATION

**ComSlab® PANEL DECKING**— shall be positively fastened to the supporting structure to avoid movement during construction and excessive deflection during placement of concrete. The fastening frequency of main fasteners is 1 per trough at each panel end at **610 mm (24 in.)** on centre along the support structure. The ComSlab® deck panels shall bear a minimum of **50 mm (2 in.)** onto the support structure. When fastening panels to structural steel work, use heavy-duty shot-fired pins or self-drilling fasteners as designed and specified by the engineer of record. For brick, block and concrete, the decking shall be fastened using adequate masonry fasteners as designed and specified by the engineer of record. The bottom flange of the End Closure shall be fastened to the supporting structure with 1 fastener per module at **610 mm (24 in.)** on centre, or as specified by the engineer of record.

In addition to the main fasteners, the top flanges of the End Closures shall be fastened to the decking, one fastener per module, either centred or **610 mm (24 in.)** on centre. Side-lap Washers shall be fastened at **350 mm (13.8 in.)** centres along the bottom trough, using **No. 14 1/4 - 14 x 1** self-drilling fasteners or better. The location of the fasteners is pre-punched on the male trough flange, which overlaps the female trough flange.

**NOTE 1:** Every side-lap fastener shall include a Side-lap Washer. This washer is required to properly attach the individual steel deck panels together.

**NOTE 2:** When a suspended ceiling is used, the minimum thread length of the fastener is **25 mm (1 in.)**.

**NOTE 3:** ComSlab® decking can be end cantilevered as shown in the “Suggested Construction Details” section on page 10. When side cantilevers are required, stub beams or brackets shall be provided by the structural steel fabricator, as designed by the engineer of record. Cantilevers shall also be assessed for reinforcement by the engineer of record.

**END CLOSURES** – To minimize grout loss at the profile ends during concrete placement, End Closures are provided to contain the concrete. These closures are manufactured from **1.37 mm (0.054 in.)** galvanized steel, generally **1830 mm (6 ft)** long or longer for angle cut installations. End Closures shall be fastened to the support structure at maximum intervals of **610 mm (24 in.)**, using shot-fired pins, self-drilling fasteners or as specified by the engineer of record. Apart from minimizing grout loss during concrete placement, these End Closures provide strength to prevent web crippling of the steel deck and proper alignment of the decking during construction. When used in conjunction with hot-rolled steel beams, these End Closures provide concrete cover to the steel beam for fire resistance.



**PLACING OF ComSlab® DECK** – Install deck progressively (male to female flange overlap) and fasten at **350 mm (13.8 in.)** on centre with Side-lap Washers and self-drilling fasteners.



**SIDE-LAP WASHERS** – Since the ComSlab deck acts in part compositely with the concrete, Side-lap Washers are important connecting elements. These washers are pre-punched to receive the self-drilling fastener.





## CONSTRUCTION AND INSTALLATION GUIDELINES

### DECK INSTALLATION

**PERIMETER TRIMS** – Are required for the retention of wet concrete to the correct level at the decked floor perimeters and designed openings. They are supplied in **3 m (10 ft)** lengths of galvanized steel. Perimeter Trims are usually fastened by shot-fired pins to the structural steel or by self-drilling fasteners to the support structure at **610 mm (24 in.)** on centre, or as specified by the engineer of record.

**RESTRAINT STRAPS** – The top of the perimeter edge trim is connected to the decking with Restraint Straps at approximately **400 mm (16 in.)** on centre using either pop rivets or self-drilling fasteners. The Restraint Strap can be adjusted to suit the pitch and alignment of the perimeter edge trim.

**RIB REINFORCEMENT AND MESH PLACEMENT** – The ComSlab® design requires that one steel reinforcing bar be placed in each rib profile. The bar size can vary from **10 M (0.394 in.)** to **35 M (1.38 in.)** in diameter. The bars shall be placed on Rebar Supports which ensure a **40 mm (1.57 in.)** spacing from the bottom flange to the underside of the reinforcing bars. Spacing of the Rebar Supports shall be in accordance with good practice guidelines, and not exceeding **1220 mm (48 in.)** on centre. To ensure both vertical and horizontal stability during concrete placement, the reinforcing bars shall be tied down periodically through the Side-lap Washers with **1.21 mm (0.0476 in.)** diameter tie wiring. It is recommended that a minimum standard shrinkage and temperature reinforcing mesh of **152x152xMW18.7xMW18.7 (6x6x6/6)** be placed above the top of the steel decking and positioned towards the top of the slab, or as specified by the engineer of record.

**TEMPORARY SUPPORTS** – When the design span exceeds the maximum unshored spans, the wet concrete weight and construction loads shall be supported by adding temporary supports (shoring), as designed by the engineer of record. Where temporary supports are required, it is important that:

- Beams and the support structure have adequate strength to support the construction loads as designed and specified by the engineer of record.
- Shoring is normally placed at midspan or at other suitable intervals, as required.
- Shoring beams shall provide a minimum bearing width of **100 mm (4 in.)**.
- The shoring structure shall remain in place until the concrete has reached **75%** of its design strength, or as specified by the engineer of record.

**CONCRETE PLACEMENT** – Concrete shall be placed in accordance with **CSA A23.1-09**. Before starting concrete placement, steel decking shall be cleared of dirt, grease and debris, which could adversely influence the composite slab performance. Care shall be taken to avoid concrete heaping in any area during concrete placement. Typical construction live loads have been accounted for in the load tables. Should additional construction loading be required, approval by the engineer of record is required.

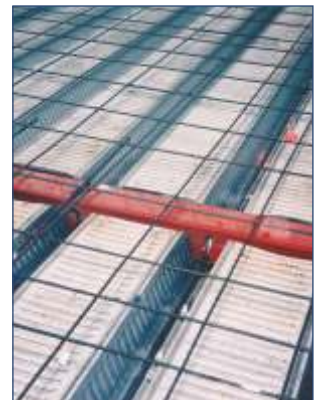



## CONSTRUCTION AND INSTALLATION GUIDELINES

### OTHER CONSIDERATIONS

**PENETRATIONS** – Penetrations through the floor decking shall be cut after the concrete has cured. Before placing concrete, any openings shall be boxed out with form work as specified by the engineer of record. The following guidelines are suggested for isolated openings at right angles to the deck span, or as specified by the engineer of record:

- Up to **300 mm (12 in.)** square penetrations centred on the top of the profile of the deck is acceptable without additional reinforcement, other than the minimum shrinkage and temperature mesh.
- Up to **425 mm (16.7 in.)** width by **1000 mm (39.4 in.)** length opening with additional reinforcement.
- Openings larger than **425 mm (16.7 in.)** require structural steel framing as specified by the engineer of record.
- Close grouping of openings transverse to the profile shall be treated as one opening, requiring additional reinforcement as specified by the engineer of record.
- After the slab has reached **75%** of the required concrete compressive strength, a nibbler, power saw or coring machine can be used to cut out openings in the top profile with the approval by the engineer of record.



**SERVICE HOLES** – Refer to table on page 13 for size and location of round holes through ComSlab® ribs. Sleeves shall be fastened in place before concrete placement. Cut-out of holes shall be done only after the concrete has reached **75%** of its design strength, or as specified by the engineer of record.



**COLUMNS AND ComSlab® DECKING** – The steel deck can be cut and fitted to accommodate various column shapes to minimize grout loss. Where no supporting steel work is provided, steel angle brackets shall be provided to support the steel decking, as specified by the engineer of record.



**HANGER SYSTEM** – The geometry of the ribs allows for the suspension of services from the profile top flange between ribs. Pre-set threaded rod hangers are easily installed before the concrete is placed. Consult your mechanical and electrical consultants, and installation contractors for accepted specifications.



**CEILING HANGER SYSTEMS** – Ceilings can be suspended directly from the bottom of the steel deck.

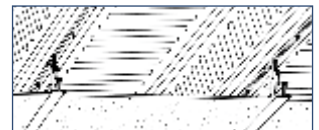

**IN-FLOOR RADIANT HEAT** – Install flat sheets of wire mesh or other equivalent material, i.e. **10 mm** reinforcing bar @ **560 mm (22 in.)** on centre commonly used.



**UNDERSIDE VIEW** – The installed ribbed ceiling provides suitable substrate for direct finishing; applying additional fire safety protection; enhanced acoustical treatment and finishing with a variety of finished ceiling materials: drywall, post paint, ceiling grid & tile.







# COMSLAB.



## SUGGESTED CONSTRUCTION DETAILS

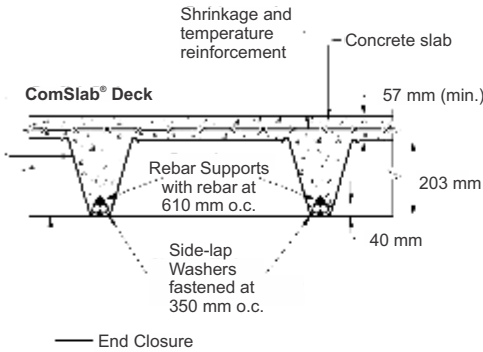

**END CLOSURE DETAIL**

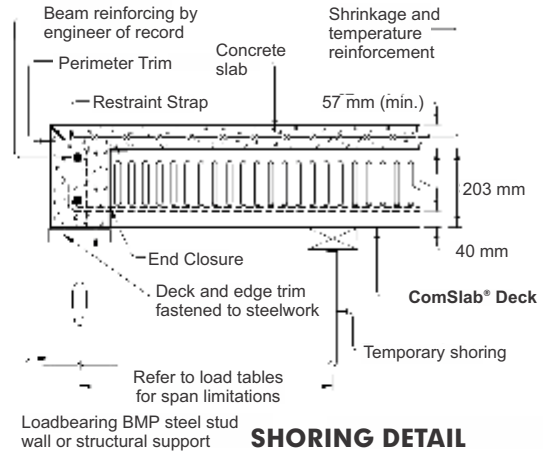

**SHORING DETAIL**

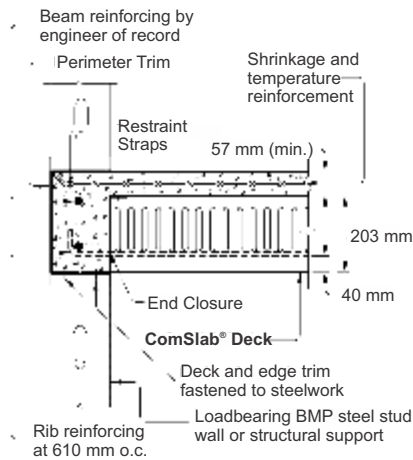

**END BEARING DETAIL**

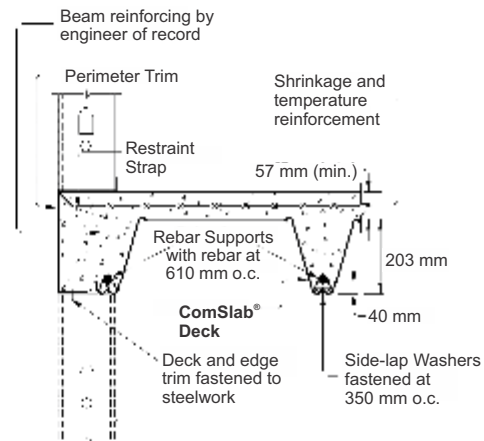

**PERIMETER BEARING DETAIL**

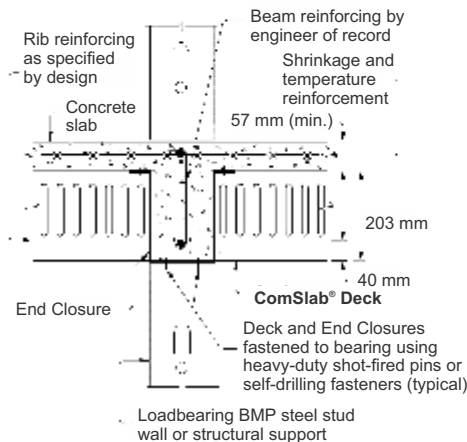

**WALL CONNECTION DETAIL**

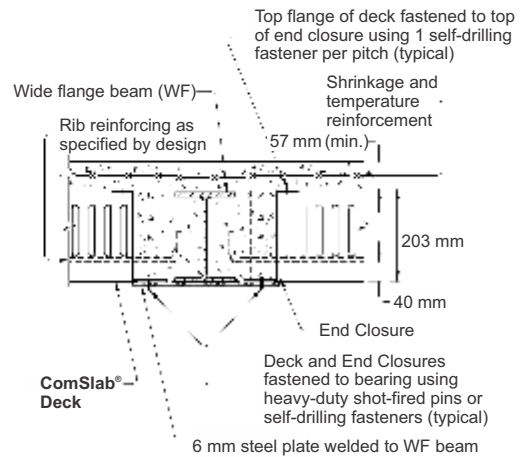

**WIDE FLANGE BEAM DETAIL**

**NOTE:** The above examples of construction applications for ComSlab® are illustrative only and should only be used with the final approval of the engineer of record.



# COMSLAB.



## SUGGESTED CONSTRUCTION DETAILS

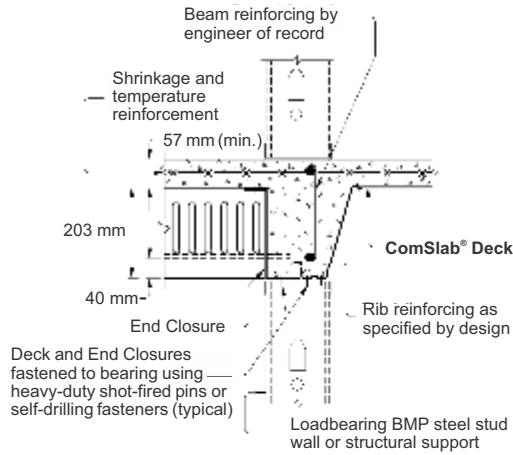

**PANEL DIRECTION CHANGE DETAIL**

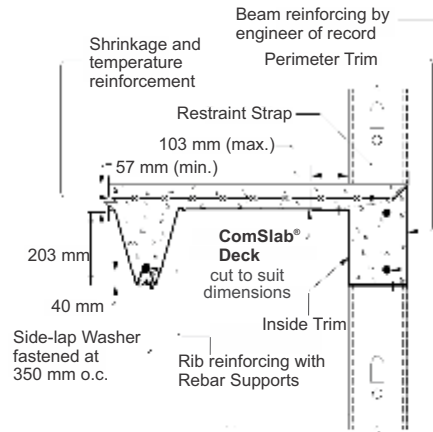

**SIDE PERIMETER BEARING DETAIL**

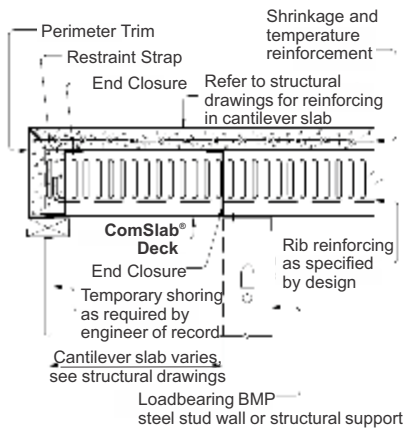

**END CANTILEVER DETAIL**

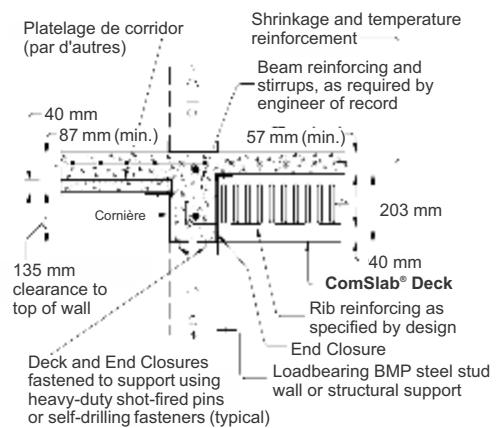

**CORRIDOR BEARING DETAIL**

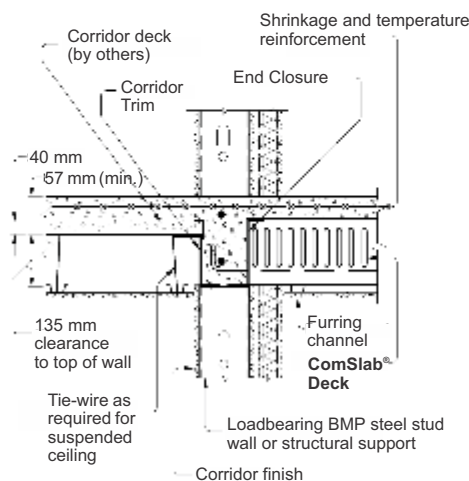

**CORRIDOR FINISHING DETAIL**

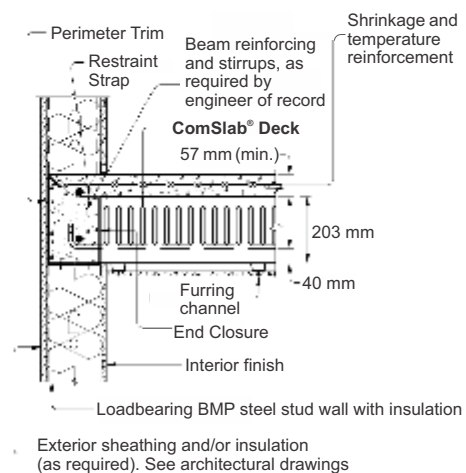

**END BEARING FINISHING DETAIL**

**NOTE:** The above examples of construction applications for ComSlab® are illustrative only and should only be used with the final approval of the engineer of record.





## SUGGESTED CONSTRUCTION DETAILS

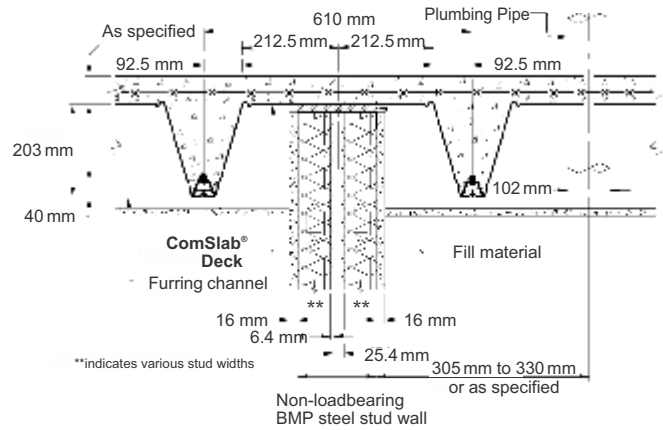
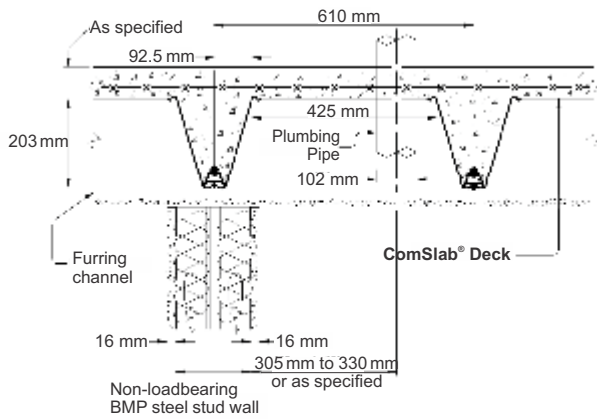

### SUGGESTED CLEARANCE NEAR PLUMBING STACKS

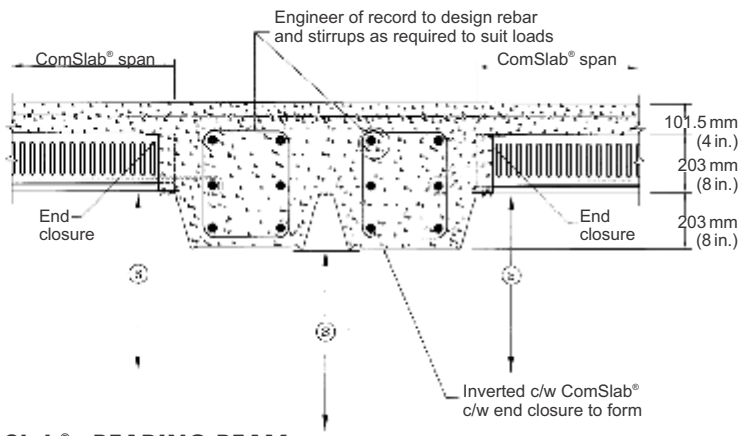
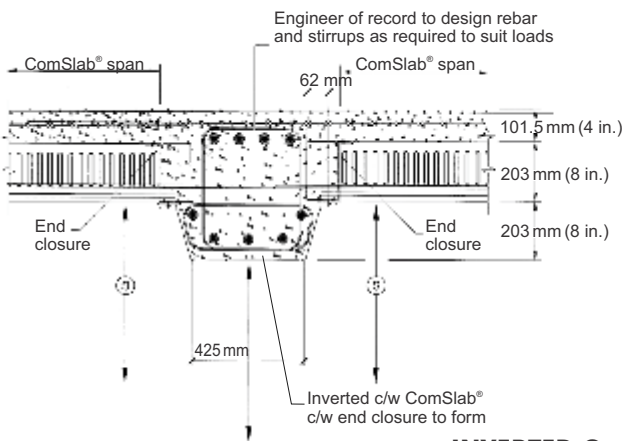

### INVERTED ComSlab® - BEARING BEAM

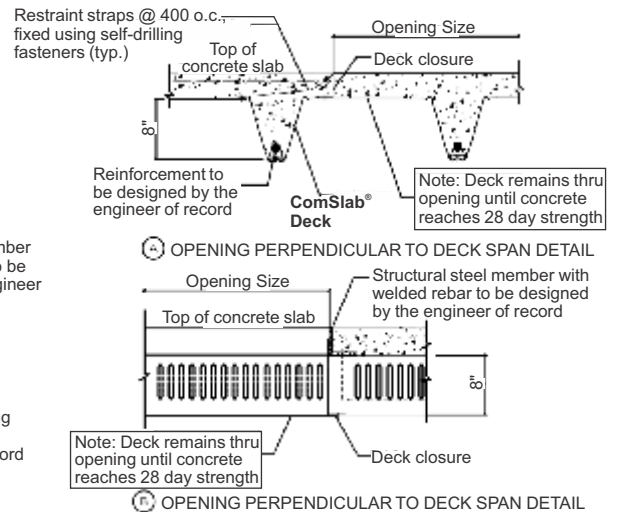
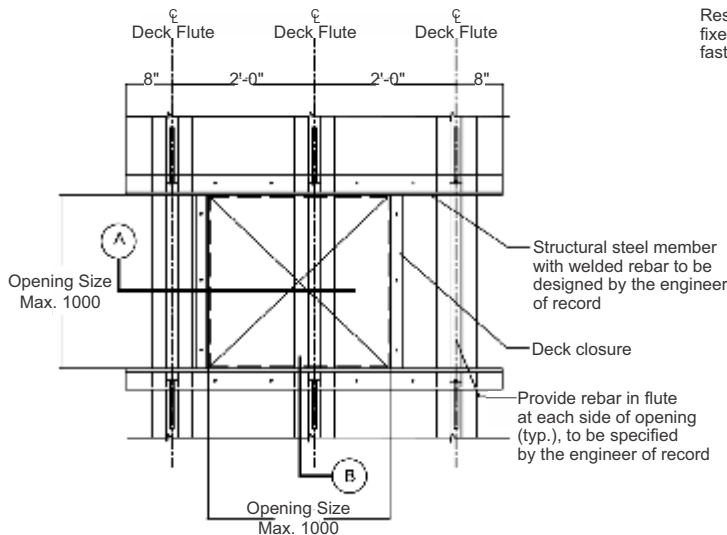

### ComSlab® CUT-THROUGH RIB REBAR DETAIL OPENING

**NOTE:** The above examples of construction applications for ComSlab® are illustrative only and should only be used with the final approval of the engineer of record.



## FIRE RESISTANCE & ACOUSTIC PERFORMANCE

### ComSlab® FIRE RATINGS & TESTED ACOUSTICAL PERFORMANCE

#### FIRE SAFETY PERFORMANCE TESTS

##### Unprotected Fire Rated Assemblies



##### Protected Fire Rated Assemblies

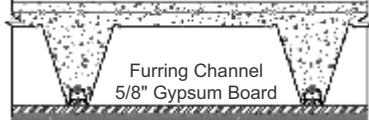

Design No.	Rating HR*	Minimum Concrete Topping	Total Slab Depth	Assembly
ULC D500	2.0	90 mm	293 mm	Protected
ULC F909	1.0	64 mm	267 mm	Unprotected
ULC F918	1.5	90 mm	293 mm	
ULC F918	2.0	110 mm	313 mm	Protected
UL D504	2.0	3.50 in.	11.5 in.	Protected
UL D930	1.0	2.50 in.	10.5 in.	Unprotected
UL D930	1.5	3.50 in.	11.5 in.	
UL D989	2.0	4.25 in.	12.25 in.	

\* Valid for both restrained condition (no span limitation) and unrestrained condition (up to 32'10").

**NOTES ON FIRE RESISTANCE RATINGS:** All rated assemblies are determined on the basis of results of tests conducted in accordance with **CAN/ULC S101** (Canada) and **UL 263** (USA) fire endurance tests of building construction and materials. Testing conducted using full-scale built floors, loaded to capacity and subjected to the standard time-temperature curve of 1,260°C.

#### ACOUSTICAL PERFORMANCE

<p><b>STC 47</b> NGC # 5009077 <b>IIC 21</b> NGC # 7009076</p> <p>Top of concrete slab Comslab Deck</p>	<p><b>STC 56</b> NGC # 5009050</p> <p>Top of concrete slab Comslab Deck 7/8" Furring channel @ 24" o.c. attached to ribs @ 24" o.c. 5/8" Type X Gypsum board</p>	<p><b>STC 58</b> NGC # 5009047</p> <p>Top of concrete slab Comslab Deck 1/2" Resilient channel @ 24" o.c. attached to ribs with sappers @ 24" o.c. 5/8" Type X Gypsum board</p>
<p><b>STC 59</b> NGC # 5009048 <b>IIC 33</b> NGC # 7009078</p> <p>Top of concrete slab Comslab Deck 1/4" Rubber Pad @ Furring channel fast point 4ft 7/8" Furring channel @ 24" o.c. attached to ribs @ 24" o.c. 5/8" Type X Gypsum board</p>	<p><b>STC 49</b> NGC # 5014012</p> <p>Top of concrete slab Comslab Deck</p>	<p><b>STC 58</b> NGC # 5014013 <b>IIC 31</b> NGC # 7014020</p> <p>Top of concrete slab Comslab Deck 7/8" Furring channel @ 24" o.c. attached to ribs @ 24" o.c. 5/8" Type X Gypsum board</p>
<p><b>STC 51</b> NGC # 5014039</p> <p>Top of concrete slab Comslab Deck</p>	<p><b>STC 57</b> NGC # 5014038</p> <p>Top of concrete slab Comslab Deck 7/8" Furring channel @ 24" attached to ribs @ 24" o.c. 5/8" Type X Gypsum board</p>	<p><b>STC 61</b> NGC # 5014048 <b>IIC 39</b> NGC # 7014059</p> <p>Top of concrete slab 1/4" Rubber Pad @ Furring channel fast point 4ft Comslab Deck 7/8" Furring channel @ 24" o.c. attached to ribs @ 24" o.c. 5/8" Type X Gypsum board</p>

**NOTES ON ACOUSTICAL PERFORMANCE:** Acoustic tests are based on **ASTM E90 (STC)** and **ASTM E492 (IIC)**. Sound loss and sound transmission are measured by a series of instruments from which the ratings are calculated for design.





# COMSLAB.



## ComSlab® DETAILS

### TYPICAL ComSlab® ROUND SERVICE HOLE DETAILS

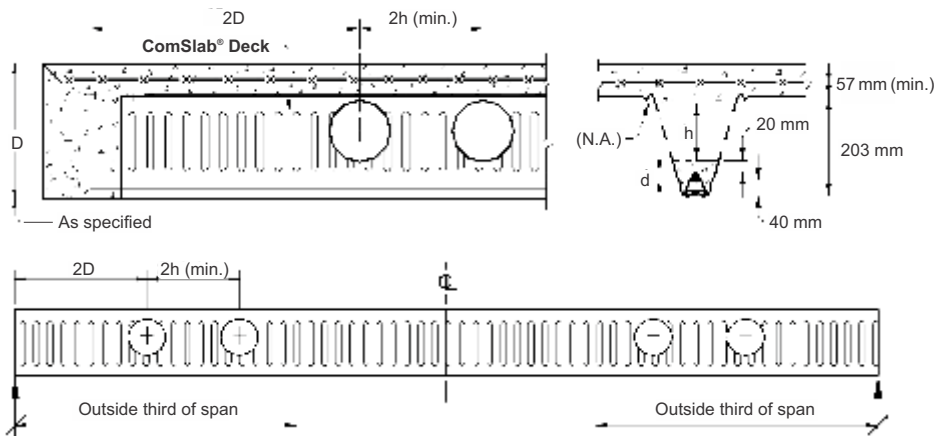

#### NOTATIONS:

D = Overall Slab Depth  
d = Rebar diameter  
h = Maximum hole diameter  
N.A. = Neutral Axis

### ComSlab® MAXIMUM HORIZONTAL OPENING TABLE

Maximum Hole Diameter	Bar Size/Nominal Rebar Diameter (mm)					
	10 M 11.3 mm	15 M 16.0 mm	20 M 19.5 mm	25 M 25.2 mm	30 M 29.9 mm	35 M 35.7 mm
h (mm)	130	125	121	116	111	105
h (in.)	5.1	4.9	4.7	4.5	4.3	4.1

### ComSlab® CONCRETE VOLUME VALUES FOR ESTIMATING

SI UNITS	Slab Thickness (mm)	260	270	280	290	300	310	320	330
	Concrete Volume (m <sup>3</sup> /10m <sup>2</sup> )		0.971	1.07	1.17	1.27	1.37	1.47	1.57
IMPERIAL UNITS	Slab Thickness (in.)	10.5	11.0	11.5	12.0	12.5	13.0	13.5	14.0
	Concrete Volume (yd <sup>3</sup> /100 ft <sup>2</sup> )		1.26	1.42	1.57	1.72	1.88	2.03	2.19

TABLE NOTES: • Does not include concrete over bearing structure.

### REINFORCING BAR INFORMATION

Nominal Bar Designation	Actual Values				Mass per Unit Length	
	Diameter		Area		kg/m	lb/ft.
	mm	in.	mm <sup>2</sup>	in. <sup>2</sup>		
10M	11.3	0.445	100	0.155	0.785	0.527
15M	16.0	0.630	200	0.310	1.57	1.06
20M	19.5	0.768	300	0.465	2.36	1.58
25M	25.2	0.992	500	0.775	3.93	2.64
30M	29.9	1.18	700	1.09	5.50	3.69
35M	35.7	1.41	1000	1.55	7.85	5.27

#### TABLE NOTES

- 20 mm (0.787 in.) of concrete is required above each rebar.
- Clear distance from the bottom of each rebar is 40 mm (1.57 in.) minimum.
- The spacing between any two holes shall not be less than 2h.
- No more than 2 holes shall be placed side by side, with the end distance spacing not less than 2D.
- Hole(s) shall be positioned in the outside thirds of span, as shown above.







# COMSLAB.

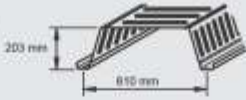

## ComSlab® DETAILS

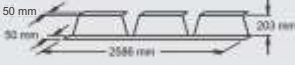
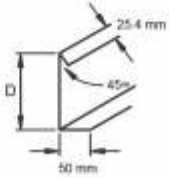
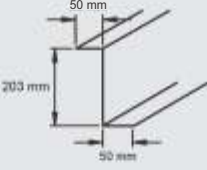
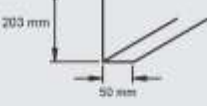
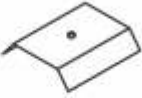
### ComSlab® STEEL DECK AND ACCESSORIES

MATERIALS	THICKNESS		WEIGHT		PACKAGING Pieces
	mm	in.	SI	Imperial	
<b>ComSlab® STEEL DECK (Z275 FINISH)</b> 	0.953	0.0375	12.6 kg/m <sup>2</sup>	2.58 lb/ft <sup>2</sup>	30 pieces per bundle cut to length
	1.257	0.0495	16.6 kg/m <sup>2</sup>	3.41 lb/ft <sup>2</sup>	
<b>90° END CLOSURES (Z275 FINISH)</b> 	1.37	0.054	2.98 kg/m or 5.44 kg/pc	1.75 lb/ft. or 10.5 lb/pc	50 pieces per bundle
<b>45° END CLOSURES (Z275 FINISH)</b> 	1.37	0.054	3.5 kg/m or 6.38 kg/pc	1.71 lb/ft. or 14.5 lb/pc	50 pieces per bundle
<b>PERIMETER TRIMS (Z275 FINISH)</b>  <p>D = overall slab depth</p>	1.37	0.054	17.7 kg/pc to 20.4 kg/pc	39 lb/pc to 45 lb/pc	10 pieces per bundle 10 ft. lengths
<b>INSIDE TRIMS (Z180 FINISH)</b> 	0.838	0.033	9.1 kg/pc	20 lb/pc	10 pieces per bundle 10 ft. lengths
	1.09	0.043	11.3 kg/pc	25 lb/pc	
<b>CORRIDOR TRIMS (Z180 FINISH)</b> 	1.37	0.054	13.6 kg/pc	30 lb/pc	
<b>SIDE-LAP WASHERS (Z180 FINISH)</b> 	1.09	0.043	11.3 kg per carton	25 lb per carton	500 pieces per carton
<b>REBAR SUPPORT CHAIR</b> 	0.838	0.033	20.4 kg per carton	45 lb per carton	300 pieces per carton
<b>RESTRAINT STRAPS (Z180 FINISH)</b> 	0.838	0.033	4.54 kg per bundle	10 lb per bundle	50 pieces per bundle
<b>FASTENERS</b> No.14 1/4 - 14 X 1" Hex S.D. Zinc  <b>SCREWS</b> No.8 x 1/2" Wafer S.D. Zinc			1.81 kg per carton	4 lb per carton	300 pieces per carton
			1.81 kg per carton	4 lb per carton	1500 pieces per carton





## DESIGN CRITERIA AND TECHNICAL DATA

### USE OF DEFLECTION PARAMETERS

#### SI Units

$$L^3 = \frac{DP \times 10^3}{DC \times w_d}$$

Where:

- L = Span length in **metres** or **feet**
- DP = Deflection parameter from load table
- DC = Deflection value, such as 360
- w<sub>d</sub> = Deflection live load in **kPa** or **psf**

#### Examples:

##### SI Units

- Base steel thickness – 0.953 mm
- Nominal bar designation – 30M
- Slab depth – 260 mm
- Deflection live load – 1.9 kPa
- From table on page 18, DP = 918
- Assume DC = 360

$$L^3 = \frac{918 \times 10^3}{360 \times 1.9}, \quad L = 11.0 \text{ m}$$

#### Imperial Units

$$L^3 = \frac{DP \times 10^6}{DC \times w_d}$$

##### Imperial Units

- Base steel thickness – 0.0375 in.
- Nominal bar designation – 25M
- Slab depth – 10.5 in.
- Deflection live load – 40 psf
- From table on page 19, DP = 668
- Assume DC = 480

$$L^3 = \frac{668 \times 10^6}{480 \times 40}, \quad L = 32.6 \text{ ft.}$$

#### DEFLECTION DUE TO SLAB WEIGHT

The deflection due to the slab weight can be calculated as follows. The calculation is based on the uncracked moment of inertia of the section and the deflection parameter, SWDP, can be obtained from the ComSlab® design data tables on pages 18 and 19.

##### Imperial Units

$$\delta_{sw} = \frac{SWDP \times (L)^4}{10^6} = \text{in.}$$

L = feet

##### SI Units

$$\delta_{sw} = \frac{SWDP \times (L)^4}{10^3} = \text{mm}$$

L = metres



## UNSHORED SPAN REQUIREMENTS

### 1.0 kPa CONSTRUCTION LIVE LOAD

Number of Lines Required	0.953 mm Steel Thickness - Metric							
	Max. Unshored Span in Meters for Shoring Lines							
	Total Slab Thickness (mm)							
	260	270	280	290	300	310	320	330
Not Required	4.3	4.2	4.1	3.9	3.8	3.7	3.6	3.5
1@1/2 Span	6.5	6.0	5.6	5.3	5.0	4.7	4.4	4.2
2@1/3 Span	10.0	9.3	8.6	8.1	7.6	7.2	6.8	6.5

Number of Lines Required	1.26 mm Steel Thickness - Metric							
	Max. Unshored Span in Meters for Shoring Lines							
	Total Slab Thickness (mm)							
	260	270	280	290	300	310	320	330
Not Required	5.6	5.5	5.4	5.3	5.2	5.1	5.0	4.9
1@1/2 Span	10.9	10.1	9.5	8.9	8.4	7.9	7.5	7.1
2@1/3 Span	<b>10.4</b>	<b>10.8</b>	<b>11.0</b>	<b>11.0</b>	<b>11.0</b>	<b>11.0</b>	<b>11.0</b>	11.0

### 2.0 kPa CONSTRUCTION LIVE LOAD

Number of Lines Required	0.953 mm Steel Thickness - Metric							
	Max. Unshored Span in Meters for Shoring Lines							
	Total Slab Thickness (mm)							
	260	270	280	290	300	310	320	330
Not Required	3.8	3.7	3.6	3.5	3.4	3.3	3.3	3.2
1@1/2 Span	5.2	5.0	4.7	4.4	4.3	4.0	3.9	3.7
2@1/3 Span	8.0	7.7	7.2	6.8	6.5	6.2	6.0	5.7

Number of Lines Required	1.26 mm Steel Thickness - Metric							
	Max. Unshored Span in Meters for Shoring Lines							
	Total Slab Thickness (mm)							
	260	270	280	290	300	310	320	330
Not Required	5.0	4.9	4.8	4.7	4.6	4.5	4.4	4.3
1@1/2 Span	8.8	8.4	7.9	7.5	7.2	6.8	6.5	6.2
2@1/3 Span	11.0	11.0	11.0	11.0	10.8	10.5	10.1	9.6

### 21 psf CONSTRUCTION LIVE LOAD

Number of Lines Required	0.0375" Steel Thickness - Imperial							
	Max. Unshored Span in Feet for Shoring Lines							
	Total Slab Thickness							
	10.5"	11.0"	11.5"	12.0"	12.5"	13.0"	13.5"	14.0"
Not Required	13.8	13.3	12.9	12.4	12.0	11.6	11.3	10.9
1@1/2 Span	20.0	18.3	16.9	15.7	14.6	13.6	12.7	11.9
2@1/3 Span	30.8	28.2	26.1	24.2	22.6	21.0	19.6	18.3

Number of Lines Required	0.0495" Steel Thickness - Imperial							
	Max. Unshored Span in Feet for Shoring Lines							
	Total Slab Thickness							
	10.5"	11.0"	11.5"	12.0"	12.5"	13.0"	13.5"	14.0"
Not Required	18.1	17.6	17.2	16.8	16.4	15.9	15.5	15.1
1@1/2 Span	33.7	30.9	28.5	26.5	24.8	23.2	21.9	20.6
2@1/3 Span	<b>36.0</b>	<b>36.0</b>	<b>36.0</b>	<b>36.0</b>	<b>36.0</b>	35.9	33.8	32.0

### 42 psf CONSTRUCTION LIVE LOAD

Number of Lines Required	0.0375" Steel Thickness - Imperial							
	Max. Unshored Span in Feet for Shoring Lines							
	Total Slab Thickness							
	10.5"	11.0"	11.5"	12.0"	12.5"	13.0"	13.5"	14.0"
Not Required	12.1	11.8	11.5	11.2	10.9	10.7	10.4	10.2
1@1/2 Span	16.8	15.6	14.6	13.7	12.9	12.1	11.5	10.9
2@1/3 Span	25.6	23.8	22.3	20.9	19.7	18.6	17.7	16.8

Number of Lines Required	0.0495" Steel Thickness - Imperial							
	Max. Unshored Span in Feet for Shoring Lines							
	Total Slab Thickness							
	10.5"	11.0"	11.5"	12.0"	12.5"	13.0"	13.5"	14.0"
Not Required	16.4	15.9	15.5	15.1	14.7	14.4	14.1	13.8
1@1/2 Span	28.4	26.4	24.6	23.1	21.8	20.6	19.5	18.5
2@1/3 Span	36.0	36.0	36.0	35.4	33.4	31.6	29.9	28.5

Lengths shown in bold italics in the above tables are limited to the maximum spans based on strength/deflection considerations.





## SPAN TABLES - IMPERIAL

40 psf LIVE LOAD								
Rib Rebar Size @ 24 in. O.C.	Maximum Allowable Single Span (feet)							
	15 psf SIDL							
	0.0375 in. Steel Thickness							
	Total Slab Thickness (in.)							
	10.5	11.0	11.5	12.0	12.5	13.0	13.5	14.0
10M	22.0	22.5	22.5	22.5	23.0	23.0	23.0	23.0
15M	25.0	25.0	25.5	25.5	25.5	25.5	26.0	26.0
20M	27.5	28.0	28.0	28.0	28.0	28.0	28.5	28.5
25M	31.5	32.0	32.0	32.0	32.5	32.5	32.5	32.5
30M	33.0	34.5	35.0	35.0	35.0	35.0	35.0	35.0
35M	34.5	36.0	36.0	36.0	36.0	36.0	36.0	36.0
	0.0495 in. ComSlab® Steel Thickness							
10M	23.0	23.0	23.0	23.0	23.0	23.0	23.0	23.0
15M	26.0	26.0	26.0	26.0	26.0	26.0	26.0	26.0
20M	29.0	29.0	29.0	29.0	29.0	29.0	29.0	29.0
25M	33.0	33.0	33.0	33.0	33.0	33.0	33.0	33.0
30M	34.0	35.5	36.0	36.0	36.0	36.0	36.0	36.0
35M	36.0	36.0	36.0	36.0	36.0	36.0	36.0	36.0

25 psf SIDL								
Rib Rebar Size @ 24 in. O.C.	Maximum Allowable Single Span (feet)							
	0.0375 in. Steel Thickness							
	Total Slab Thickness (in.)							
	10.5	11.0	11.5	12.0	12.5	13.0	13.5	14.0
10M	21.5	21.5	22.0	22.0	22.0	22.0	22.0	22.5
15M	24.0	24.5	24.5	24.5	25.0	25.0	25.0	25.0
20M	26.5	26.5	27.0	27.0	27.0	27.5	27.5	27.5
25M	30.5	30.5	31.0	31.0	31.5	31.5	31.5	32.0
30M	31.5	32.5	34.5	34.5	35.0	35.0	35.0	35.0
35M	32.5	34.0	35.5	36.0	36.0	36.0	36.0	36.0
	0.0495 in. ComSlab® Steel Thickness							
10M	23.0	23.0	23.0	23.0	23.0	23.0	23.0	23.0
15M	26.0	26.0	26.0	26.0	26.0	26.0	26.0	26.0
20M	28.5	28.5	29.0	29.0	29.0	29.0	29.0	29.0
25M	31.0	32.5	32.5	33.0	33.0	33.0	33.0	33.0
30M	32.0	33.5	35.0	36.0	36.0	36.0	36.0	36.0
35M	33.0	34.5	36.0	36.0	36.0	36.0	36.0	36.0

35 psf SIDL								
Rib Rebar Size @ 24 in. O.C.	Maximum Allowable Single Span (feet)							
	0.0375 in. Steel Thickness							
	Total Slab Thickness (in.)							
	10.5	11.0	11.5	12.0	12.5	13.0	13.5	14.0
10M	20.5	20.5	21.0	21.0	21.0	21.5	21.5	21.5
15M	23.0	23.5	23.5	23.5	24.0	24.0	24.0	24.5
20M	25.5	25.5	26.0	26.0	26.0	26.5	26.5	26.5
25M	29.5	29.5	30.0	30.0	30.5	30.5	30.5	31.0
30M	30.0	31.0	33.0	33.5	33.5	34.0	34.0	34.5
35M	31.0	32.5	33.5	35.0	36.0	36.0	36.0	36.0
	0.0495 in. ComSlab® Steel Thickness							
10M	23.0	23.0	23.0	23.0	23.0	23.0	23.0	23.0
15M	25.0	25.5	26.0	26.0	26.0	26.0	26.0	26.0
20M	27.0	27.5	28.0	28.0	28.5	28.5	29.0	29.0
25M	29.5	31.0	31.5	32.0	32.0	32.5	32.5	33.0
30M	30.5	32.0	33.0	35.0	35.0	35.5	36.0	36.0
35M	31.5	33.0	34.5	35.5	36.0	36.0	36.0	36.0

100 psf LIVE LOAD								
Rib Rebar Size @ 24 in. O.C.	Maximum Allowable Single Span (feet)							
	15 psf SIDL							
	0.0375 in. Steel Thickness							
	Total Slab Thickness (in.)							
	10.5	11.0	11.5	12.0	12.5	13.0	13.5	14.0
10M	17.5	17.5	18.0	18.0	18.5	18.5	19.0	19.0
15M	19.5	20.0	20.5	20.5	21.0	21.0	21.5	21.5
20M	21.5	22.0	22.5	22.5	23.0	23.0	23.5	23.5
25M	25.0	25.0	25.5	26.0	26.5	26.5	27.0	27.0
30M	26.0	27.0	28.0	29.0	29.5	29.5	30.0	30.5
35M	26.5	28.0	29.0	30.5	31.5	33.0	34.0	34.5
	0.0495 in. ComSlab® Steel Thickness							
10M	19.5	20.0	20.0	20.5	21.0	21.0	21.5	21.5
15M	21.5	22.0	22.0	22.5	23.0	23.0	23.5	23.5
20M	23.0	23.5	24.0	24.5	24.5	25.0	25.5	25.5
25M	25.5	26.5	27.0	27.5	28.0	28.5	28.5	29.0
30M	26.5	27.5	29.0	30.0	30.5	31.0	31.5	32.0
35M	27.0	28.5	29.5	31.0	32.0	33.5	34.5	35.5

25 psf SIDL								
Rib Rebar Size @ 24 in. O.C.	Maximum Allowable Single Span (feet)							
	0.0375 in. Steel Thickness							
	Total Slab Thickness (in.)							
	10.5	11.0	11.5	12.0	12.5	13.0	13.5	14.0
10M	17.0	17.5	17.5	18.0	18.0	18.0	18.5	18.5
15M	19.0	19.5	20.0	20.0	20.5	20.5	21.0	21.0
20M	21.0	21.5	21.5	22.0	22.5	22.5	23.0	23.0
25M	24.5	24.5	25.0	25.5	26.0	26.0	26.5	26.5
30M	25.0	26.5	27.5	28.5	29.0	29.0	29.5	30.0
35M	26.0	27.0	28.5	29.5	31.0	32.0	33.0	33.5
	0.0495 in. ComSlab® Steel Thickness							
10M	19.0	19.5	19.5	20.0	20.5	20.5	21.0	21.0
15M	21.0	21.5	21.5	22.0	22.5	22.5	23.0	23.0
20M	22.5	23.0	23.5	24.0	24.0	24.5	25.0	25.0
25M	25.0	26.0	26.5	27.0	27.5	27.5	28.0	28.5
30M	25.5	27.0	28.0	29.0	30.0	30.5	31.0	31.0
35M	26.5	27.5	29.0	30.0	31.5	32.5	33.5	35.0

35 psf SIDL								
Rib Rebar Size @ 24 in. O.C.	Maximum Allowable Single Span (feet)							
	0.0375 in. Steel Thickness							
	Total Slab Thickness (in.)							
	10.5	11.0	11.5	12.0	12.5	13.0	13.5	14.0
10M	16.5	17.0	17.5	17.5	17.5	18.0	18.0	18.0
15M	18.5	19.0	19.5	19.5	20.0	20.0	20.5	20.5
20M	20.5	21.0	21.0	21.5	22.0	22.0	22.5	22.5
25M	23.5	24.0	24.5	25.0	25.0	25.5	26.0	26.0
30M	24.5	25.5	26.5	27.5	28.0	28.5	29.0	29.0
35M	25.5	26.5	27.5	29.0	30.0	31.0	32.5	33.0
	0.0495 in. ComSlab® Steel Thickness							
10M	18.5	19.0	19.0	19.5	20.0	20.0	20.5	20.5
15M	20.5	21.0	21.0	21.5	22.0	22.0	22.5	22.5
20M	22.0	22.5	23.0	23.0	23.5	24.0	24.0	24.5
25M	24.5	25.5	26.0	26.5	26.5	27.0	27.5	27.5
30M	25.0	26.5	27.0	28.5	29.5	30.0	30.0	30.5
35M	26.0	27.0	28.0	29.5	30.5	31.5	33.0	34.0

### TABLE NOTES

- SIDL = Super Imposed Dead Load.
- Spans are based on single span condition.
- The above tables are based on placing one reinforcement bar at each ComSlab® rib @ 24 in. O.C. Negative moment reinforcement bars to be specified by the project engineer if required.
- Temporary Shoring to be placed at equal distances at either mid or 1/3 of the spans or as specified by the shoring engineer. Consult with the project engineer.
- The above values are based on Concrete Properties: 150 lb/ft<sup>3</sup> Normal Weight; Compressive Strength of 4.35 ksi.
- Deflection Limit due to the live load is L/360.
- Temperature/Shrinkage reinforcement, full size of slab (6 x 6 x 6/6).





## DESIGN DATA - METRIC UNITS

0.953 mm STEEL THICKNESS		NORMAL DENSITY CONCRETE (2400 kg/m <sup>3</sup> )							
NOMINAL BAR DESIGNATION	SLAB THICKNESS (mm)	260	270	280	290	300	310	320	330
10M	SLAB WEIGHT (kPa)	2.42	2.66	2.89	3.13	3.36	3.60	3.83	4.07
	CONCRETE VOLUME (m <sup>3</sup> /10m <sup>2</sup> )	0.971	1.071	1.171	1.271	1.371	1.471	1.571	1.671
	DEFLECTION PARAMETER (DP)	655	729	809	894	985	1083	1187	1300
	DEFLECTION PARAMETER (SWDP)	2.60	2.54	2.48	2.42	2.34	2.27	2.19	2.12
15M	SLAB WEIGHT (kPa)	2.43	2.67	2.90	3.14	3.38	3.61	3.85	4.08
	CONCRETE VOLUME (m <sup>3</sup> /10m <sup>2</sup> )	0.971	1.071	1.171	1.271	1.371	1.471	1.571	1.671
	DEFLECTION PARAMETER (DP)	708	788	874	966	1063	1168	1280	1400
	DEFLECTION PARAMETER (SWDP)	2.50	2.45	2.39	2.33	2.26	2.19	2.12	2.04
20M	SLAB WEIGHT (kPa)	2.45	2.68	2.92	3.15	3.39	3.62	3.86	4.09
	CONCRETE VOLUME (m <sup>3</sup> /10m <sup>2</sup> )	0.971	1.071	1.171	1.271	1.371	1.471	1.571	1.671
	DEFLECTION PARAMETER (DP)	755	841	933	1030	1134	1245	1364	1490
	DEFLECTION PARAMETER (SWDP)	2.43	2.37	2.31	2.25	2.19	2.12	2.05	1.98
25M	SLAB WEIGHT (kPa)	2.47	2.71	2.94	3.18	3.41	3.65	3.88	4.12
	CONCRETE VOLUME (m <sup>3</sup> /10m <sup>2</sup> )	0.971	1.071	1.171	1.271	1.371	1.471	1.571	1.671
	DEFLECTION PARAMETER (DP)	842	938	1041	1150	1266	1389	1521	1661
	DEFLECTION PARAMETER (SWDP)	2.30	2.24	2.19	2.13	2.07	2.00	1.94	1.87
30M	SLAB WEIGHT (kPa)	2.50	2.73	2.97	3.20	3.44	3.67	3.91	4.14
	CONCRETE VOLUME (m <sup>3</sup> /10m <sup>2</sup> )	0.971	1.071	1.171	1.271	1.371	1.471	1.571	1.671
	DEFLECTION PARAMETER (DP)	918	1025	1138	1258	1385	1521	1665	1817
	DEFLECTION PARAMETER (SWDP)	2.20	2.14	2.09	2.03	1.97	1.91	1.85	1.78
35M	SLAB WEIGHT (kPa)	2.54	2.77	3.01	3.24	3.48	3.71	3.91	4.18
	CONCRETE VOLUME (m <sup>3</sup> /10m <sup>2</sup> )	0.971	1.071	1.171	1.271	1.371	1.471	1.471	1.671
	DEFLECTION PARAMETER (DP)	1015	1135	1262	1397	1540	1691	1691	2023
	DEFLECTION PARAMETER (SWDP)	2.09	2.03	1.98	1.92	1.86	1.80	1.80	1.68

1.26 mm STEEL THICKNESS		NORMAL DENSITY CONCRETE (150 lb/ft <sup>3</sup> )							
NOMINAL BAR DESIGNATION	SLAB THICKNESS (mm)	260	270	280	290	300	310	320	330
10M	SLAB WEIGHT (kPa)	2.46	2.69	2.93	3.17	3.40	3.64	3.87	4.11
	CONCRETE VOLUME (m <sup>3</sup> /10m <sup>2</sup> )	0.971	1.071	1.171	1.271	1.371	1.471	1.571	1.671
	DEFLECTION PARAMETER (DP)	727	808	894	987	1087	1193	1308	1430
	DEFLECTION PARAMETER (SWDP)	2.47	2.42	2.36	2.30	2.23	2.16	2.09	2.02
15M	SLAB WEIGHT (kPa)	2.47	2.71	2.94	3.18	3.41	3.65	3.88	4.12
	CONCRETE VOLUME (m <sup>3</sup> /10m <sup>2</sup> )	0.971	1.071	1.171	1.271	1.371	1.471	1.571	1.671
	DEFLECTION PARAMETER (DP)	778	864	957	1056	1162	1275	1396	1525
	DEFLECTION PARAMETER (SWDP)	2.38	2.33	2.28	2.22	2.16	2.09	2.02	1.95
20M	SLAB WEIGHT (kPa)	2.48	2.72	2.96	3.19	3.43	3.66	3.90	4.13
	CONCRETE VOLUME (m <sup>3</sup> /10m <sup>2</sup> )	0.971	1.071	1.171	1.271	1.371	1.471	1.571	1.671
	DEFLECTION PARAMETER (DP)	823	915	1013	1117	1229	1348	1476	1612
	DEFLECTION PARAMETER (SWDP)	2.32	2.27	2.21	2.16	2.09	2.03	1.96	1.90
25M	SLAB WEIGHT (kPa)	2.51	2.74	2.98	3.22	3.45	3.69	3.92	4.16
	CONCRETE VOLUME (m <sup>3</sup> /10m <sup>2</sup> )	0.971	1.071	1.171	1.271	1.371	1.471	1.571	1.671
	DEFLECTION PARAMETER (DP)	906	1008	1117	1232	1356	1487	1627	1776
	DEFLECTION PARAMETER (SWDP)	2.21	2.16	2.10	2.05	1.99	1.93	1.87	1.80
30M	SLAB WEIGHT (kPa)	2.54	2.77	3.01	3.24	3.48	3.71	3.95	4.18
	CONCRETE VOLUME (m <sup>3</sup> /10m <sup>2</sup> )	0.971	1.071	1.171	1.271	1.371	1.471	1.571	1.671
	DEFLECTION PARAMETER (DP)	980	1092	1210	1336	1471	1613	1765	1927
	DEFLECTION PARAMETER (SWDP)	2.12	2.07	2.02	1.96	1.90	1.84	1.78	1.73
35M	SLAB WEIGHT (kPa)	2.57	2.81	3.04	3.28	3.51	3.71	3.99	4.22
	CONCRETE VOLUME (m <sup>3</sup> /10m <sup>2</sup> )	0.971	1.071	1.171	1.271	1.371	1.471	1.571	1.671
	DEFLECTION PARAMETER (DP)	1073	1198	1330	1471	1620	1620	1947	1947
	DEFLECTION PARAMETER (SWDP)	2.03	1.97	1.92	1.86	1.80	1.80	1.69	1.69

### TABLE NOTES

- The "SLAB WEIGHT" is made up of the self weight of the steel deck, the reinforcing bar and the concrete slab.
- For explanation of deflection parameters DP & SWDP, see pg 15. • "SLAB THICKNESS" is measured from top of concrete to bottom of steel deck.
- Concrete volumes listed above do not include concrete over bearing structure.



## DESIGN DATA - IMPERIAL UNITS

0.0375" STEEL THICKNESS		NORMAL DENSITY CONCRETE (150 lb/ft <sup>3</sup> )							
NOMINAL BAR DESIGNATION	SLAB THICKNESS (in.)	10.5	11.0	11.5	12.0	12.5	13.0	13.5	14.0
10M	SLAB WEIGHT (psf)	53.9	60.2	66.4	72.7	78.9	85.2	91.4	97.7
	CONCRETE VOLUME (yd. <sup>3</sup> /100 ft. <sup>2</sup> )	1.26	1.42	1.57	1.72	1.88	2.03	2.19	2.34
	DEFLECTION PARAMETER (DP)	520	593	673	761	856	960	1074	1198
	DEFLECTION PARAMETER (SWDP)	0.871	0.845	0.816	0.785	0.752	0.719	0.685	0.652
15M	SLAB WEIGHT (psf)	54.2	60.4	66.7	72.9	79.2	85.4	91.7	97.9
	CONCRETE VOLUME (yd. <sup>3</sup> /100 ft. <sup>2</sup> )	1.26	1.42	1.57	1.72	1.88	2.03	2.19	2.34
	DEFLECTION PARAMETER (DP)	562	641	727	821	923	1034	1155	1287
	DEFLECTION PARAMETER (SWDP)	0.839	0.814	0.786	0.757	0.726	0.694	0.662	0.631
20M	SLAB WEIGHT (psf)	54.4	60.7	66.9	73.2	79.4	85.7	91.9	98.2
	CONCRETE VOLUME (yd. <sup>3</sup> /100 ft. <sup>2</sup> )	1.26	1.42	1.57	1.72	1.88	2.03	2.19	2.34
	DEFLECTION PARAMETER (DP)	599	684	776	875	984	1101	1229	1368
	DEFLECTION PARAMETER (SWDP)	0.813	0.788	0.762	0.733	0.703	0.673	0.642	0.612
25M	SLAB WEIGHT (psf)	55.0	61.2	67.5	73.7	80.0	86.2	92.5	98.7
	CONCRETE VOLUME (yd. <sup>3</sup> /100 ft. <sup>2</sup> )	1.26	1.42	1.57	1.72	1.88	2.03	2.19	2.34
	DEFLECTION PARAMETER (DP)	668	763	866	977	1097	1228	1368	1521
	DEFLECTION PARAMETER (SWDP)	0.769	0.745	0.719	0.692	0.665	0.636	0.608	0.581
30M	SLAB WEIGHT (psf)	55.5	61.7	68.0	74.2	80.5	86.7	93.0	99.2
	CONCRETE VOLUME (yd. <sup>3</sup> /100 ft. <sup>2</sup> )	1.26	1.42	1.57	1.72	1.88	2.03	2.19	2.34
	DEFLECTION PARAMETER (DP)	730	834	947	1069	1201	1343	1497	1662
	DEFLECTION PARAMETER (SWDP)	0.736	0.711	0.686	0.660	0.633	0.607	0.580	0.554
35M	SLAB WEIGHT (psf)	56.3	62.5	68.8	75.0	81.3	87.5	93.8	100.0
	CONCRETE VOLUME (yd. <sup>3</sup> /100 ft. <sup>2</sup> )	1.26	1.42	1.57	1.72	1.88	2.03	2.19	2.34
	DEFLECTION PARAMETER (DP)	807	925	1052	1189	1336	1495	1666	1849
	DEFLECTION PARAMETER (SWDP)	0.698	0.673	0.648	0.622	0.597	0.572	0.547	0.522

0.0495" STEEL THICKNESS		NORMAL DENSITY CONCRETE (150 lb/ft <sup>3</sup> )							
NOMINAL BAR DESIGNATION	SLAB THICKNESS (in.)	10.5	11.0	11.5	12.0	12.5	13.0	13.5	14.0
10M	SLAB WEIGHT (psf)	54.7	60.9	67.2	73.4	79.7	85.9	92.2	98.4
	CONCRETE VOLUME (yd. <sup>3</sup> /100 ft. <sup>2</sup> )	1.26	1.42	1.57	1.72	1.88	2.03	2.19	2.34
	DEFLECTION PARAMETER (DP)	576	656	743	839	943	1057	1181	1315
	DEFLECTION PARAMETER (SWDP)	0.827	0.803	0.776	0.747	0.716	0.685	0.654	0.622
15M	SLAB WEIGHT (psf)	55.0	61.2	67.5	73.7	80.0	86.2	92.5	98.7
	CONCRETE VOLUME (yd. <sup>3</sup> /100 ft. <sup>2</sup> )	1.26	1.42	1.57	1.72	1.88	2.03	2.19	2.34
	DEFLECTION PARAMETER (DP)	616	702	795	896	1007	1127	1258	1400
	DEFLECTION PARAMETER (SWDP)	0.800	0.776	0.750	0.723	0.693	0.663	0.633	0.604
20M	SLAB WEIGHT (psf)	55.2	61.5	67.7	74.0	80.2	86.5	92.7	99.0
	CONCRETE VOLUME (yd. <sup>3</sup> /100 ft. <sup>2</sup> )	1.26	1.42	1.57	1.72	1.88	2.03	2.19	2.34
	DEFLECTION PARAMETER (DP)	652	743	841	948	1065	1191	1329	1477
	DEFLECTION PARAMETER (SWDP)	0.777	0.754	0.729	0.702	0.674	0.645	0.616	0.588
25M	SLAB WEIGHT (psf)	55.7	62.0	68.2	74.5	80.7	87.0	93.2	99.5
	CONCRETE VOLUME (yd. <sup>3</sup> /100 ft. <sup>2</sup> )	1.26	1.42	1.57	1.72	1.88	2.03	2.19	2.34
	DEFLECTION PARAMETER (DP)	718	819	928	1046	1174	1313	1463	1624
	DEFLECTION PARAMETER (SWDP)	0.739	0.716	0.692	0.666	0.640	0.613	0.586	0.559
30M	SLAB WEIGHT (psf)	56.3	62.5	68.8	75.0	81.3	87.5	93.8	100.0
	CONCRETE VOLUME (yd. <sup>3</sup> /100 ft. <sup>2</sup> )	1.26	1.42	1.57	1.72	1.88	2.03	2.19	2.34
	DEFLECTION PARAMETER (DP)	778	888	1006	1135	1274	1424	1586	1761
	DEFLECTION PARAMETER (SWDP)	0.710	0.686	0.662	0.637	0.612	0.586	0.561	0.536
35M	SLAB WEIGHT (psf)	57.1	63.3	69.6	75.8	82.1	88.3	94.6	100.8
	CONCRETE VOLUME (yd. <sup>3</sup> /100 ft. <sup>2</sup> )	1.26	1.42	1.57	1.72	1.88	2.03	2.19	2.34
	DEFLECTION PARAMETER (DP)	853	975	1108	1250	1405	1571	1749	1942
	DEFLECTION PARAMETER (SWDP)	0.677	0.653	0.628	0.604	0.579	0.555	0.531	0.507

### TABLE NOTES

- The "SLAB WEIGHT" is made up of the self weight of the steel deck, the reinforcing bar and the concrete slab.
- For explanation of deflection parameters DP & SWDP, see pg 15. • "SLAB THICKNESS" is measured from top of concrete to bottom of steel deck.
- Concrete volumes listed above do not include concrete over bearing structure.

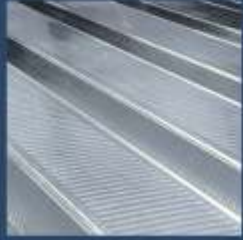

# BAILEY<sup>®</sup>

METAL PRODUCTS LIMITED



COMCDN11BW16-1000

## COMSLAB<sup>®</sup>

COMSLAB LONG SPAN COMPOSITE FLOOR SYSTEM

[sales@bmp-group.com](mailto:sales@bmp-group.com) • [www.comslab.ca](http://www.comslab.ca)



### MONTREAL

525 Avenue Edward VII  
Dorval, QC H9P 1E7  
Tel. (514) 735-3455  
800-263-3455  
Fax. (514) 735-5052

### TORONTO

1 Caldari Road  
Concord, ON L4K 3Z9  
Tel. (905) 738-9267  
800-668-2154  
Fax. (905) 738-5712

### CALGARY

3924 27th Street NE  
Calgary, AB T1Y 5K7  
Tel. (403) 248-3536  
800-665-2013  
Fax. (403) 248-0288

### EDMONTON

101-5710 Roper Road NW  
Edmonton, AB T6B 3G7  
Tel. (780) 462-5757  
800-563-1751  
Fax. (780) 450-3378

### VANCOUVER

7715 Anvil Way  
Surrey, BC V3W 6A2  
Tel. (604) 590-5100  
800-818-2666  
Fax. (604) 590-5105