

ComSlab® LONG SPAN CONCRETE FLOOR SYSTEM

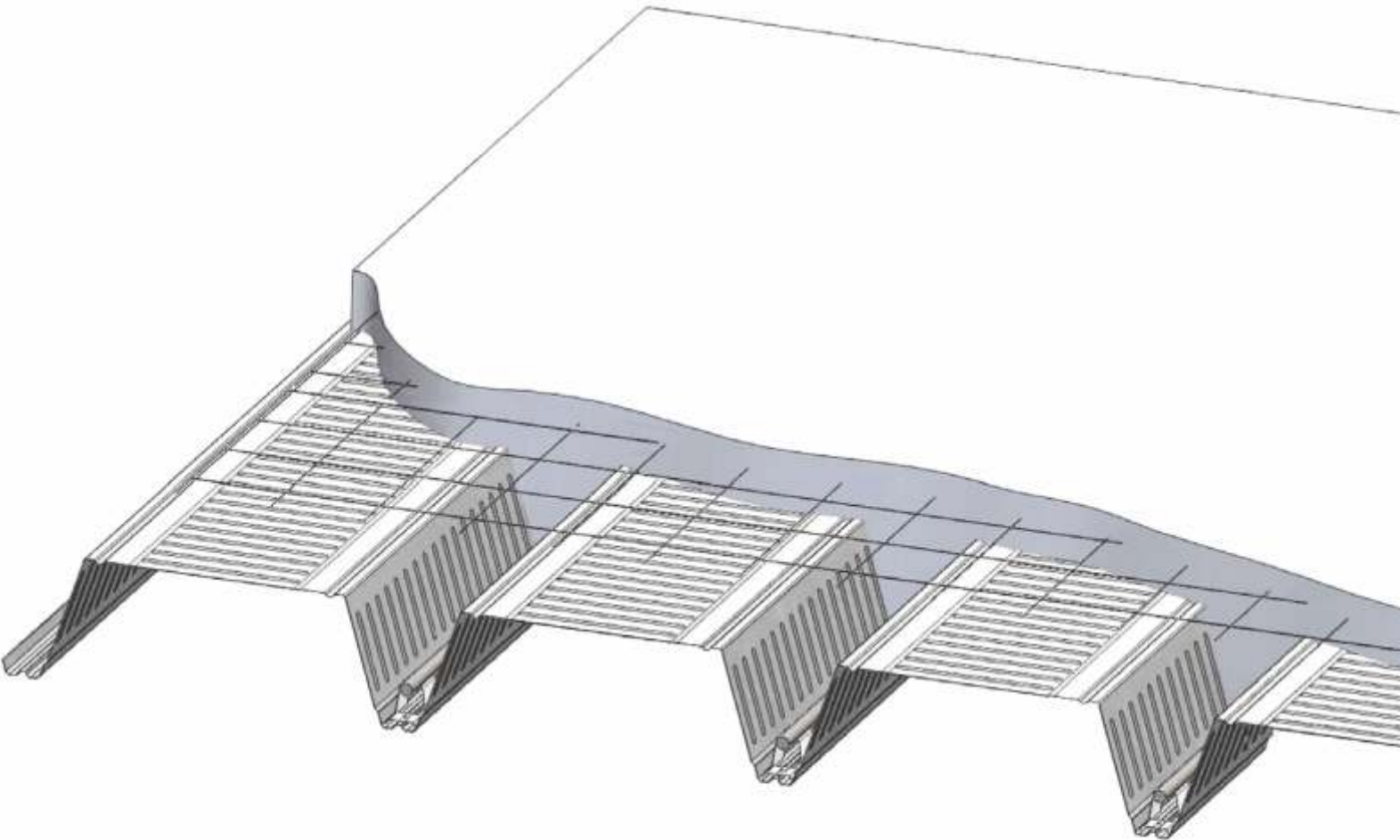

Technical and Structural Information





ComSlab® CONCRETE FLOOR SYSTEM

Proven, reliable and cost-effective

ComSlab® CONCRETE FLOOR SYSTEM

The ComSlab® System from Bailey is a two hour fire rated, structurally superior composite floor. It's specially designed for use in hotels, multi story residential buildings, long-term care facilities, multi family residential units, schools and/or office buildings. ComSlab® will accommodate all wall systems, including lightweight steel framing, structural steel, masonry or poured concrete, insulated concrete forms or wood framing construction. It is a proven, reliable, and cost-effective composite steel deck installed in almost 1000 buildings to date.

A quality product, manufactured by Bailey Metal Products Limited, ComSlab® is lightweight and self-seating for long-span floor requirements. Easy to work with, it can be rapidly installed in even the tightest work environments. It is a practical solution, especially when building in, and around, tight downtown locations where large truck access is limited.

The ComSlab® System is designed for applications and use in all building construction. Its unique concept allows for flexible design options. It easily accommodates the placement of all services, duct work and conduit. ComSlab® sections can be supplied pre-cut to your specifications for even greater time and material savings.

ComSlab® is best used in facilities where fire rating is paramount and it can be adapted to many other environmentally friendly building opportunities. It's an economical and creative option for the construction of mezzanines, dry-deck roofing and roof-top green spaces or gardens.

ComSlab® IS A LEED FRIENDLY PRODUCT FOR RECYCLABILITY, WASTE REDUCTION AND CLEAN AIR BUILDING.



TABLE OF CONTENTS

Introduction.....	2
Benefits.....	4
Design Criteria and Technical Data.....	5-7
Steel Deck Cross Section Properties.....	5
Live Load Calculations.....	7
Deflection due to Slab Weight.....	7
Specifications.....	8-11
References Standards.....	8-9
Warranty.....	10
Span Tables.....	12
Construction and Installation Guidelines.....	13-16
Other Considerations.....	15
Examples of Construction Applications.....	17-19
Fire Ratings and Acoustical Performance.....	20
Round Service Hole Details.....	21
Maximum Round Service Hole Diameters.....	21
Concrete Volume Values for Estimating.....	21
Reinforcing Bar Information.....	21
Steel Deck and Accessories.....	22
User Notes.....	23



ComSlab® LONG SPAN CONCRETE FLOOR SYSTEM

WHY CHOOSE ComSlab® FOR YOUR NEXT FLOOR PROJECT?

- **Cost-effective**
- **Unique benefits** not found in pre-cast or cast-in-place reinforced concrete construction
- **All services are easily accommodated** by the ComSlab® design profile
- **Easy to work with** and adaptable to all wall systems
- **Two Hour Fire Rating** – Best in the industry!
- Designed for **long span construction** of up to 10 m (32'10")
- Ideal for **fast-track construction**, especially in tight working spaces

ComSlab® BENEFITS



Rigid Steel Deck
Provides safe unshored work platform



Multi Span
Meets a wide range of architectural designs



Sound Transmission Class
Meets and exceeds building code requirements



Long Clear Span
Up to 10 metres (32' 10"), depth as shallow as 10.5 inches



Fast Track Construction
Accommodates duct work, conduit and other building services



Design Flexibility for 45° Assembly
Lightweight interlock design for rapid installation



DESIGN CRITERIA AND TECHNICAL DATA

This catalogue provides technical and structural information for the ComSlab® composite concrete slab system. All calculations, whenever applicable, were based on ANSI/SDI C-2011. Design load tables are also presented, as well as various construction applications to assist the designer in detailing common structural assemblies. Additional assistance regarding the ComSlab® Composite Floor System construction method may be obtained by contacting the Bailey Metal Products sales office in your area.

The structural load tables and technical information contained in this catalogue were prepared by Dr. R.M. Schuster, P.Eng., Professor Emeritus of Structural Engineering at the University of Waterloo.

ComSlab® CROSS SECTION PROPERTIES

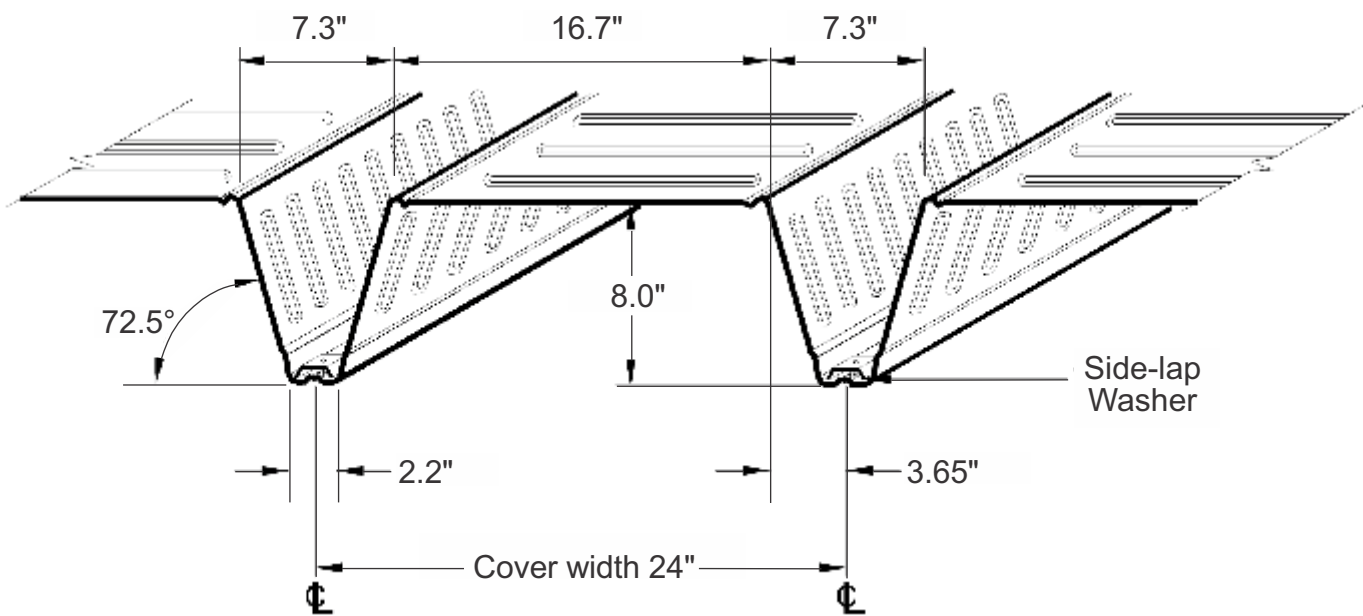

IMPERIAL UNITS

Base Steel Thickness (in.)	Profile Depth (in.)	Profile Weight (psf)	A_g^1 (in. ² /ft.)	A_e^2 (in. ² /ft.)	S_p^3 (in. ³ /ft.)	I_x^4 (in. ⁴ /ft.)
0.0375	8.00	2.58	0.727	0.297	0.690	3.41
0.0495	8.00	3.41	0.960	0.444	1.287	5.62

TABLES NOTES

¹ A_g = Gross cross sectional area of profile per unit width.

² A_e = Effective cross sectional area of profile per unit width.

³ S_p = Effective section modulus of profile per unit width for positive bending.

⁴ I_x = Effective moment of inertia of profile per unit width.



DESIGN CRITERIA AND TECHNICAL DATA

DESIGN CRITERIA

MATERIALS

- Steel deck meets the requirements of **ASTM A653** Standard Specification of Steel Sheet, Zinc-coated (Galvanized) by the Hot-dip Process, Structural (Physical) Quality. The guaranteed minimum yield strength is **50 ksi** with a minimum zinc coating mass of **275 g/m² Z 275 (G90)** total both sides. Steel deck base thickness is **0.0375 inches** or **0.0495 inches**.
- Reinforcing steel meets the requirements of **ASTM A615 GR60**. Guaranteed minimum yield strength is **58.0 ksi**. The clear distance of each reinforcing bar from the bottom of the steel deck is **1.57 inches**.
- Concrete is assumed to have a minimum cylinder strength of **4.35 ksi**, with a maximum aggregate size of **0.75 inches**. Normal density structural concrete is **(150 lb/ft³)**.

ALLOWABLE STRESS DESIGN (ASD)

- **Strength** – Allowable stress design principles were used in the development of the structural load tables, i.e., the factored resistance under consideration, **$\Phi R \geq$ the effect of the factored loads**. This is in accordance with the International Building Code. Since the self weight of the steel deck and the concrete have already been included in the structural load tables, the maximum specified load (from the appropriate structural table) shall be: **$> (LL + 1.2/1.6DL)$** , where:

- LL** – Specified live load
- DL** – Specified superimposed dead load
- 1.2** – Dead load factor
- 1.6** – Live load factor

- **Serviceability** – If deflection controls, the maximum specified load (from the appropriate structural table) shall be: **$\geq (LL + DL)$** .

SECTION PROPERTIES OF STEEL DECK

All structural section properties of the steel deck were calculated in accordance with **AISI S100-07**. See page 5 for section properties and cross section details.

STRUCTURAL LOAD TABLES

Structural load tables provide maximum specified loads and were established in accordance with **ANSI/SDI C-2011** and **ACI 318-08**.

Shoring During Construction

Shoring requirements for the steel deck during construction were established in accordance with **ACI 318-08**. The following strength and deflection criteria were used:

- **Strength** – Calculations were based on the combined loads due to the wet concrete, the steel deck and certain construction live loads. Minimum construction live loads applied separately are:
 - 1) **20 psf** uniform load.
 - 2) **137 lb/ft** transverse line load at the centre of the span.
- **Serviceability** – Calculated deflections were based on the uniform load of concrete slab and steel deck, and the maximum deflections were limited to **L/180** or **0.787 inches**.

In each structural load table, the maximum unshored span conditions are given. Using this information, one can determine the number of shores required for any given span condition.

- **Load Tables** – Both the strength and deflection criteria were considered in accordance with **ANSI/SDI C-2011**, as follows:

- **Strength** – Flexure was the only criteria that was considered in the calculations since shear-bond is not a mode of failure (specified concentrated live load was included in the strength calculations).

- **Serviceability** – The calculated deflections due to specified superimposed loads (LL + DL) were based on a uniform load with the maximum deflection limited to **L/360**. The modular ratio for normal density concrete was taken as **10** and the moment of inertia is the average of the uncracked and cracked moment of inertias. For use of the deflection parameter, **DP**, see example on page 7. To determine the deflection due to the slab weight, also see page 7.

- **Use of Load Tables** – Please see example on page 7 for use of structural tables.

STRUCTURAL TESTING

Structural ComSlab® composite slab tests were carried out at the University of Salford, England by Prof. D. O'Leary (April, 1993). Based on these tests, shear-bond was not a mode of failure. Typically, composite slab systems fail in shear-bond. However, since the ComSlab® composite slab system also has reinforcing steel, shear-bond is not a governing failure mode.



DESIGN CRITERIA AND TECHNICAL DATA

ComSlab® EXAMPLE

Given the following information, check the adequacy of the ComSlab® floor system:

Given:

- Yield Stress: $F_y = 50.0$ ksi
- Single span length = 24.5 ft.
- Fire rating required = 1 hr. D930*
- Reinforcing steel bar yield strength = 58 ksi
- Concrete – Normal density = 150 lb/ft³
- * UL Design No. D930

Specified Loads

- Superimposed dead load (DL)
 - a) floor finish = 10.5 psf
 - b) partitions = 20.0 psf
- Total superimposed DL = 30.5 psf
- Live load (LL) = 100.0 psf

Total Load = $\frac{1.2}{1.6} (DL) + LL = \frac{1.2}{1.6} (30.5) + 100 = 123$ psf

Use of load table for 1 hr. D930 rating:

From the Bailey ComSlab® tables, use 0.0375" steel deck thickness, #9 rebar at 10.5 in. slab thickness and 24.5 ft. span. The maximum specified load is 144 psf, which is controlled by deflection and is checked as follows:
 $(DL + LL) = (30.5 + 100) = 130.5$ psf

Since 144 > 130.5 OK

NOTE: Maximum unshored span is 13.4 ft.: one shore support is required at mid span.



USE OF DEFLECTION PARAMETER

Imperial Units

$$w_d = \frac{SLDP \times 10^6}{DC \times (L)^3}$$

Where:

- w_d = Maximum specified deflection load in **psf**,
- SLDP = Deflection parameter from load table,
- DC = Deflection constant such as 360,
- L = Span length in **feet**

Example:

- Base steel thickness – 0.0375 in.
- Nominal bar diameter – #9 bar
- Slab depth – 10.5 in.
- Span length, L – 25 ft
- From Bailey ComSlab® tables, SLDP = 763
- Assume DC = 400

$$w_d = \frac{763 \times 10^6}{400 \times (25)^3} = 122$$
 psf

For DC = 360, $w_d = 136$ psf

NOTE: For confirmation of values, see appropriate load tables.

DEFLECTION DUE TO SLAB WEIGHT

The deflection due to the slab weight can be calculated as follows. The calculation is based on the uncracked moment of inertia of the section and the deflection parameter, SWDP, can be obtained from the load tables.

Imperial Units

$$\delta_{sw} = \frac{SWDP \times (L)^4}{10^6} = \text{in.}$$

L = feet



ComSlab® SPECIFICATIONS

PART 1 - GENERAL

1.01 RELATED DOCUMENTS

- A** All of the Contract Documents, including General and Supplementary Conditions and Division 01 General Requirements, apply to the work of this section.

1.02 SCOPE

- A** The work of this section includes, but is not limited to the following:
 - 1** Furnish all the materials and services for the fabrication of the composite floor system in accordance with these specifications and applicable drawings.
 - 2** Fully coordinate the composite floor system with the structural, mechanical, electrical and architectural components of the building.
- B** Related Sections: Other specification sections which directly relate to the work of this section include, but are not limited to the following:
 - 1** Section 03 30 00 – Cast-in-Place Concrete
 - 2** Section 03 32 00 – Concrete Reinforcement

1.03 REFERENCE STANDARDS

- A** The following standards and publications are applicable to the extent referenced in the text.
- B** American Society for Testing and Materials (ASTM):
 - A653/A653M-06 Standard Specification for Steel Sheet, Zinc-Coated (Galvanized) or Zinc-Iron Alloy-Coated (Galvannealed) by the Hot-Dip Process.
 - A1008/A1008M-07 Standard Specification for Steel, Sheet, Cold-Rolled, Carbon, Structural, High-Strength Low-Alloy and High-Strength Low Alloy with Improved Formability.
 - A307-04 Standard Specification for Carbon Steel Externally Threaded Standard Fasteners.
 - A325-06 Standard Specification for Structural Bolts, Steel, Heat-Treated, 120/105 ksi Minimum Tensile Strength.
 - A529-05 Standard Specification for High-Strength Carbon-Manganese Steel of Structural Quality.
 - A563-04a Standard Specification for Carbon and Alloy Steel Nuts.
 - A572/A572M-06 Standard Specification for High-Strength Low-Alloy Columbium-Vanadium Steels of Structural Quality.

1.03 REFERENCE STANDARDS (continued)

- C39 Standard Test Method for Compressive Strength of Cylinders Concrete Specifications.
- C1513-04 Standard Specification for Steel Tapping Screws for Cold-Formed Steel Framing Connections.
- F436-07a Standard Specification for Hardened Steel Washers.
- C** American Concrete Institute (ACI):
 - 301 Specifications for Structural Concrete.
 - 318-08 Building Code Requirements for Structural Concrete.
- D** American Institute of Structural Concrete (AISC):
 - Specification for the Design of Cold-Formed Steel Structural Members.
- E** American Welding Society (AWS):
 - D1.1 Structural Welding Code - Steel
 - D1.3 Structural Welding Code - Sheet Steel
- F** Steel Joist Institute
- G** Society for Protective Coatings (SSPC):
 - Painting Manual, 2005.
- H** Steel Deck Institute (SDI):
 - Manual of Construction with Steel Deck
- I** Steel Joist Institute (SJI):
 - Standard Specification and Load Tables for Steel Joists and Joist Girders.
- J** Canadian Standards Association (CSA):
 - S136-07 North American Specification for Design of Cold-Formed Steel Structural Members
 - G30.18-09 Carbon Steel Bars for Concrete Reinforcement
 - A23.1-09 Concrete Materials and Methods of Concrete Construction
- K** Canadian Sheet Steel Building Institute (CSSBI):
 - S2-2008 Criteria for the Testing of Composite Slabs
 - 12M-2008 Standard for Composite Steel Decks
 - S3-2008 Criteria for the Design of Composite Slabs
- L** National Building Code of Canada:
 - NBC 2005
- M** Wamock, A.C.C.:
 - Factors Affecting Sound Transmission Loss



ComSlab® SPECIFICATIONS

1.03 REFERENCE STANDARDS (continued)

- N** Underwriter's Laboratories of Canada (ULC):
List of Equipment & Materials, Volume II - Building Materials
- O** Underwriter's Laboratories, Inc. (UL):
Fire Resistance Directory, Volume I

1.04 SYSTEM DESCRIPTION

The ComSlab® System from Bailey Metal Products is a two hour fire-rated, structurally superior composite floor. It is specially designed for use in hotels, multi-story residential buildings, long-term care facilities, multi-family residential units, schools and/or office buildings. ComSlab® will accommodate all wall systems, including lightweight steel framing, structural steel, masonry or poured concrete, insulated concrete forms or wood framing construction. It's a proven, reliable and cost-effective composite steel deck installed in more than 1,000 buildings to date.

A quality product, manufactured by Bailey Metal Products Limited, ComSlab® is lightweight and self-seating for long-span flooring requirements. It's easy to work with and can be rapidly installed in even the tightest of work environments. It is a practical solution, especially when building in and around light downtown locations where large truck access is limited.

The ComSlab® System is designed for application and use in all building construction. Its unique concept allows for flexible design options, and it can easily accommodate the placement of all services, duct work and conduit. Sections can be supplied pre-cut to your specifications for even greater time and material savings.

ComSlab® is best used in facilities where fire rating is paramount and it can be adopted to many other environmentally friendly building opportunities. It's an economical, creative option for the construction of mezzanines, roof-top green spaces, or any elevated concrete slabs.

ComSlab® IS A **LEED FRIENDLY** PRODUCT FOR RECYCLABILITY, WASTE REDUCTION AND CLEAN AIR BUILDING.

1.05 SUBMITTALS

- A** General: Submit in accordance with Section 01 33 00.
- B** Product Data: Submit manufacturer's product literature and installation instructions, use limitations and recommendations.
- C** Subcontractor's approval by Manufacturer: Submit document stating manufacturer's acceptance of the subcontractor.
- D** Warranty: Submit a sample of manufacturer's warranty identifying the terms and conditions stated in 1.09.
- E** Shop Drawings: Detailed erection drawings shall be submitted by the purchaser to the Architect, Engineer, General Contractor or representative for approval, showing material lists, mark numbers, types, locations, spacing of floor plans and accessories, showing method of attachment to supporting members.

1.05 SUBMITTALS (continued)

- E** Shop Drawings (continued): Contract drawing notes relative to the ComSlab® Composite Floor System shall be considered a part of the Specifications as though fully set forth herein.

Shop drawings, prepared only from approved erection drawings, shall be used for fabrication and erection.

Figured dimensions only shall be used. Scaling drawings shall NOT be used.

1.06 QUALITY ASSURANCE

- A** Welding Materials and Methods of Fabrications:
Manufacturer's standard shop practice.
- B** Welder's Qualifications:
Certify that each welder is AWS certified in accordance with AWS D1.1
- C** Materials:
For each type of material required to complete the work of this section, provide primary materials which are the products of a single manufacturer.
- D** Manufacturer's Representative:
Arrange to have a trained representative of the manufacturer on site periodically to review installation procedures.

1.07 DELIVERY, STORAGE & HANDLING

- A** Materials should be delivered to site in manufacturer's unopened containers with original labels attached and bearing the following information:
 - 1** Name of material.
 - 2** Manufacturer's batch codes, including date of manufacture.
 - 3** Materials Safety Data Sheets.
- B** Care shall be exercised at all times to avoid damage to composite floor system components during loading, storing & erecting. Damaged decking must be replaced.
- C** Deck panels are supplied in bundles of up to 30 sheets. Each bundle can weigh up to 5,500 pounds. Individual decking elements can twist when lifted, so care shall be taken.
- D** Deck panels shall be stored on timber supports, clear of the ground. The bundles shall be positioned on and/or in the area indicated on the layout drawings. The bundles shall be placed with the pre-punched holes in the lap on the side, unless otherwise noted on the layout drawing.

1.08 PROJECT CONDITIONS

- A** Work should be performed only when existing and forecasted weather conditions are within the limits established by the composite floor manufacturer.



ComSlab® SPECIFICATIONS

1.08 PROJECT CONDITIONS (continued)

- B** Proceed with installation only when construction and preparation is complete.
- C** Maintain work area in a neat and workmanlike condition. Remove empty cartons and rubbish from the site daily.

1.09 WARRANTY

- A** Limited Warranty: The Seller warrants that the title to the goods sold shall be free of any encumbrances and will conform, subject to standard manufacturing tolerances, to the descriptions and specifications printed and/or referenced in the product brochures applicable to the goods published by the Seller (the "Technical Data"). The Technical Data are intended as design aids to the design professional and should not be used to replace the judgement of a qualified engineer or architect. Anyone making use of the Technical Data shall assume any and all risk from such use. Although employees of the Seller are available for consultation concerning the selection of goods and required specifications, they're not authorized to warrant the suitability of any goods for any particular use or application. The Buyer shall be solely responsible for determining the adequacy of the goods for any and all intended use of the goods.
- B** The load tables and other product performance data contained in the Technical Data are valid only if the goods are installed in accordance with the instructions and specifications printed and/or referenced in the Technical Data, and the printed information shall prevail.
- C** The load tables and other product performance data contained in the Technical Data are not valid if other products are substituted for any products available for purchase from the seller.
- D** The warranty set forth in this Section is in lieu of and excludes all other warranties, express or implied, by operation of law or otherwise, including any warranty of merchantability or fitness for the Buyer's particular purpose. Under no circumstance shall the Seller be under any other liability and, in particular, shall not be liable for any consequential or indirect losses, including any financial losses.

PART 2 - PRODUCTS

2.01 MANUFACTURERS

- A** Provide ComSlab® Composite Floor System as manufactured by Bailey Metal Products Limited, Concord, Canada, phone 855-787-1980.

2.02 PRODUCTS

- A** Steel Deck Panels:
Fabricated using **Z275 (G90)** galvanized steel sheet, of either **0.036 in. (0.914 mm)** or **0.048 in. (1.22 mm)** in thickness.

2.02 PRODUCTS (continued)

- B** End Closures:
Fabricated using **Z275 (G90)** galvanized steel sheet, **0.06 in. (1.52 mm)** in thickness.
- C** Perimeter Trims:
Fabricated using **Z275 (G90)** galvanized steel sheet, **0.060 in. (1.52 mm)** in thickness.
- D** Inside Trims:
Fabricated using **Z180 (G60)** galvanized steel sheet of either **0.036 in. (0.914 mm)** or **0.048 in. (1.22 mm)** in thickness, depending on the ComSlab® steel deck thickness.
- E** Corridor Trims:
Fabricated using **Z180 (G60)** galvanized steel sheet, **0.060 in. (1.52 mm)** in thickness.
- F** Side-lap Washers:
Fabricated using **Z180 (G60)** galvanized steel sheet, **0.048 in. (1.22 mm)** in thickness.
- G** Rebar Supports:
Fabricated using **Z180 (G60)** galvanized steel sheet, **0.036 in. (0.914 mm)** in thickness.
- H** Restraint Straps:
Fabricated using **Z180 (G60)** galvanized steel sheet, minimum **0.033 in. (0.838 mm)** in thickness.

PART 3 - EXECUTION

3.01 INSPECTION

- A** Before starting any installation of composite floor systems, the installer shall thoroughly inspect all surfaces for any conditions detrimental to the proper completion of the work. Should any deficiencies exist, the General Contractor should be made aware of such in writing immediately. Do not proceed with installation until all unsatisfactory conditions are corrected.

3.02 PREPARATION

- A** Refer to manufacturer's product literature for preparation requirements. Surfaces should be structurally sound. Remove debris or any other foreign materials which may damage the composite floor system. Use repair material that are acceptable by the sheet membrane manufacturer.
- B** Installation shall be in accordance with the latest Construction Guidelines for the ComSlab® Composite Floor System. Care shall be exercised to avoid damage through careless handling during unloading, storing and erecting. Suitably qualified personnel shall install ComSlab® floor components.

3.03 INSTALLATION

- A** End Closures shall be fixed to the support structure prior to the decking being installed, using a minimum of 2 fasteners, (such as shot-fired pins or self-drilling fasteners), and using the following fastener Specification or equivalency:



ComSlab® SPECIFICATIONS

3.03 INSTALLATION (continued)

A End Closures (continued)

1 In addition to the main structural fastening, the profile top flanges are fixed to the upper flange of the End Closures using self-drilling fasteners at a frequency of 1 fastener per profile.

- a.** No. 12 x 1 inch (25.4 mm) or better, hexagon washer head, zinc coated or equivalent. The above fasteners shall be installed using a correctly set screw gun to the data available from the fastener supplier.

B Ensure that current decking drawings are being used. The ComSlab® deck panels shall be correctly fastened at each end to the bearing wall substrate with appropriate mechanical fasteners. The ComSlab® deck panels shall bear a minimum of 2 inches (50mm) onto the support structures.

C Perimeter Trims shall be fastened to the wall substrate in a true and plumb manner, using the appropriate fastener to suit the steel or concrete substrate at 13.8 in. (350mm) intervals in accordance with the data available from the fastener supplier.

D Interior deck panel closures shall be fastened to the ComSlab® deck panel with a minimum of 2 in. (50mm) overlap, fastened together with No. 12 x 1 in. (25.4mm) or better, hexagon washer head self-drilling screws spaced at 13.8 in. (350mm) on center. Panel closures shall be the equivalent thickness of the ComSlab® deck panel specified. Alternately, the ComSlab® panel can be cut longitudinally and overlapped a minimum of 3 in. (75mm) and fastened together at 12 in. (300mm) on center with 2 fasteners paired 1 in. (25.4mm) apart.

E Side-lap Washers shall be installed at 13.8 in. (350mm) along the bottom trough of each vault profile using No. 12 x 1 in. (25.4mm) or better, hexagon washer head self-drilling screws. The fastener location is indicated by pre-punched holes in the male overlap. The laps shall be correctly connected together, as they form a critical part of the flooring system.

3.03 INSTALLATION (continued)

F Rebar Supports shall be installed at 4 ft. (1220mm) on center maximum, to support the reinforcing bars (10mm to 35mm, as specified) in each vault or trough - 1.57 in. (40mm) clearance.

G Restraint Straps shall be installed 16 in. (400mm) on center, one end to the Perimeter Trim return flange and the other end to the top of the deck panel for concrete pressure restraint during the concrete placement phase of the construction.

H Shoring shall be supplied and installed by qualified personnel at the locations specified on the drawings. If in doubt, check with the supplier's technical department and the engineer of record. Shoring shall not be removed until the concrete has reached 75% of its required design strength, or as authorized by the engineer of record. Consult with the engineer of record to be sure that the shoring meets the local jurisdictional requirements before placing of concrete.

I Concrete shall be placed in accordance with ACI 318-08. Good concrete placement practices shall be carried out at all times. Refer to concrete practice guidelines before starting concrete placement.

3.04 CLEANING AND PROTECTION

A Clean welds and abrasions after erection.

B Touch up painted surfaces with same primer as originally applied.

C Touch up galvanized coatings with galvanizing repair paint; apply as recommended by manufacturer.



ComSlab® SPAN TABLES

ComSlab® SPAN TABLES

SINGLE SPAN IN FEET (ft)

DESIGN LOADS

SUPERIMPOSED (LL 40 psf + DL 25 psf)

Rebar Size	20 GA		18 GA	
	10.5	11.5	10.5	11.5
#3	20.6	21.0	23.3	23.8
#4	22.4	22.8	24.9	25.5
#5	24.6	25.0	26.7	27.3
#6	26.9	27.3	28.8	29.4
#7	29.3	29.8	31.0	31.7
#8	31.8	32.3	33.3	34.0
#9	34.3	34.9	35.6	36.4

DESIGN LOADS

SUPERIMPOSED (LL 100 psf + DL 15 psf)

Rebar Size	20 GA		18 GA	
	10.5	11.5	10.5	11.5
#3	19.9	20.5	21.7	22.5
#4	21.7	22.4	23.3	24.2
#5	23.7	24.5	25.1	26.1
#6	25.7	26.6	27.0	28.0
#7	27.8	28.7	28.7	30.0
#8	28.5	30.8	29.1	31.7
#9	29.0	31.7	29.5	32.2



CONSTRUCTION AND INSTALLATION GUIDELINES

DECKING INSTALLATION

ComSlab® PANEL DECKING— shall be positively fastened to the supporting structure to avoid movement during construction and excessive deflection during placement of concrete. The fastening frequency of main fasteners is 1 per trough at each panel end at **24 inches** on centre along the support structure. The ComSlab® deck panels shall bear a minimum of **2 inches** onto the support structure. When fastening panels to structural steel work, use heavy-duty shot-fired pins or self-drilling fasteners as designed and specified by the engineer of record. For brick, block and concrete, the decking shall be fastened using adequate masonry fasteners as designed and specified by the engineer of record. The bottom flange of the End Closure shall be fastened to the supporting structure with 1 fastener per module at **24 inches** on centre, or as specified by the engineer of record.

In addition to the main fasteners, the top flanges of the End Closures shall be fastened to the decking, one fastener per module, either centred or **24 inches** on centre. Side-lap Washers shall be fastened at **13.8 inches** centres along the bottom trough, using **No. 14 1/4 - 14 x 1** self-drilling fasteners or better. The location of the fasteners is pre-punched on the male trough flange, which overlaps the female trough flange.

NOTE 1: Every side-lap fastener shall include a Side-lap Washer. This washer is required to properly attach the individual steel deck panels together.

NOTE 2: When a suspended ceiling is used, the minimum thread length of the fastener is **1 inch**.

NOTE 3: ComSlab® decking can be end cantilevered as shown in the “Examples of Construction Applications” section on page 14. When side cantilevers are required, stub beams or brackets shall be provided by the structural steel fabricator, as designed by the engineer of record. Cantilevers shall also be assessed for reinforcement by the engineer of record.

END CLOSURES – To minimize grout loss at the profile ends during concrete placement, End Closures are provided to contain the concrete. These closures are manufactured from **0.054 inches** galvanized steel, generally **6 feet** long or longer for angle cut installations. End Closures shall be fastened to the support structure at maximum intervals of **24 inches**, using shot-fired pins, self-drilling fasteners or as specified by the engineer of record. Apart from minimizing grout loss during concrete placement, these End Closures provide strength to prevent web crippling of the steel deck and proper alignment of the decking during construction. When used in conjunction with hot-rolled steel beams, these End Closures provide concrete cover to the steel beam for fire resistance.



PLACING OF ComSlab® DECK – Install deck progressively (male to female flange overlap) and fasten at **13.8 inches** on center with Side-lap Washers and self-drilling fasteners.



SIDE-LAP WASHERS – Since the ComSlab® deck acts in part compositely with the concrete, Side-lap Washers are important connecting elements. These washers are pre-punched to receive the self-drilling fastener.





CONSTRUCTION AND INSTALLATION GUIDELINES

DECKING INSTALLATION

PERIMETER TRIMS – Are required for the retention of wet concrete to the correct level at the decked floor perimeters and designed openings. They are supplied in **10 foot** lengths of galvanized steel. Perimeter Trims are usually fastened by shot-fired pins to the structural steel or by self-drilling fasteners to the support structure at **24 inches** on center, or as specified by the engineer of record.

RESTRAINT STRAPS – The top of the perimeter edge trim is connected to the decking with Restraint Straps at approximately **16 inches** on centre using either pop rivets or self-drilling fasteners. The Restraint Strap can be adjusted to suit the pitch and alignment of the perimeter edge trim.



RIB REINFORCEMENT AND MESH PLACEMENT – The ComSlab® design requires that one steel reinforcing bar be placed in each rib profile. The bar size, as shown in the load tables, can vary from **0.394 inches** to **1.38 inches** in diameter. The bars shall be placed on Rebar Supports which ensure a spacing of **1.57 inches** from the bottom flange to the underside of the reinforcing bars. Spacing of the Rebar Supports shall be in accordance with good practice guidelines, and not exceeding **48 inches** on center. To ensure both vertical and horizontal stability during concrete placement, the reinforcing bars shall be tied down periodically through the Side-lap Washers with **0.0476 inch** diameter tie wiring. It is recommended that a minimum standard shrinkage and temperature reinforcing mesh of **6x6x6/6** be placed above the top of the steel decking and positioned towards the top of the slab, or as specified by the engineer of record.

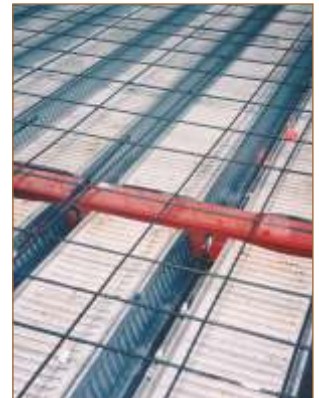

TEMPORARY SUPPORTS – When the design span exceeds the maximum unshored span shown in the load tables, the wet concrete weight and construction loads shall be supported by adding temporary supports (shoring), as designed by the engineer of record. Where temporary supports are required, it is important that:

- Beams and the support structure have adequate strength to support the construction loads as designed and specified by the engineer of record.
- Shoring is normally placed at midspan or at other suitable intervals, as required.
- Shoring beams shall provide a minimum bearing width of **4 inches**.
- The shoring structure shall remain in place until the concrete has reached **75%** of its design strength, or as specified by the engineer of record.



CONCRETE PLACEMENT – Concrete shall be placed in accordance with **ACI 318-08**. Before starting concrete placement, steel decking shall be cleared of dirt, grease and debris, which could adversely influence the composite slab performance. Care shall be taken to avoid concrete heaping in any area during concrete placement. Typical construction live loads have been accounted for in the load tables. Should additional construction loading be required, approval by the engineer of record is required.





CONSTRUCTION AND INSTALLATION GUIDELINES

OTHER CONSIDERATIONS

PENETRATIONS – Penetrations through the floor decking shall be cut after the concrete has cured. Before placing concrete, any openings shall be boxed out with form work as specified by the engineer of record. The following guidelines are suggested for isolated openings at right angles to the deck span, or as specified by the engineer of record:

- Up to **12 inch** square penetrations centered on the top of the profile of the deck is acceptable without additional reinforcement, other than the minimum shrinkage and temperature mesh.
- Up to **16.7 inch** width by **39.4 inch** length opening with additional reinforcement.
- Openings larger than **16.7 inches** require structural steel framing as specified by the engineer of record.
- Close grouping of openings transverse to the profile shall be treated as one opening, requiring additional reinforcement as specified by the engineer of record.
- After the slab has reached **75%** of the required concrete compressive strength, a nibbler, power saw or coring machine can be used to cut out openings in the top profile with the approval by the engineer of record.



SERVICE HOLES – Refer to table on page 18 for size and location of round holes through ComSlab® ribs. Sleeves shall be fastened in place before concrete placement. Cut-out of holes shall be done only after the concrete has reached **75%** of its design strength, or as specified by the engineer of record.



COLUMNS AND ComSlab® DECKING – The steel deck sheeting can be cut and fitted to accommodate various column shapes to minimize grout loss. Where no supporting steel work is provided, steel angle brackets shall be provided to support the steel decking, as specified by the engineer of record.



HANGER SYSTEM – The geometry of the ribs allows for the suspension of services from the profile top flange between ribs. Pre-set threaded rod hangers are easily installed before the concrete is placed. Consult your mechanical and electrical consultants, and installation contractors for accepted specifications.



CEILING HANGER SYSTEMS – Ceilings can be suspended directly from the bottom of the steel deck.

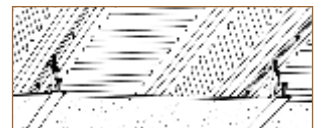



CONSTRUCTION AND INSTALLATION GUIDELINES

END CLOSURE

Install with mechanical fasteners to any lateral beam or bearing wall substrate at minimum **24 inches** on center.



PERIMETER TRIM

Install Perimeter Trims for concrete containment and alignment. The top edge is used as a screed guide to achieve the overall required concrete slab depth.



PLACING OF ComSlab® DECK

Install deck progressively (male to female flange overlap) and fasten at **13.8 inches** on center with Side-lap Washers and self-drilling fasteners.



TEMPORARY SHORING

Install in accordance with load tables based on the maximum unshored span condition. The engineer of record shall approve shoring requirement and installation.



IN-FLOOR RADIANT HEAT

Install flat sheets of wire mesh or other equivalent material, i.e. **#3** reinforcing bar, at **22 inches** on center commonly used.



PLACEMENT OF CONCRETE

Place concrete uniformly and screed to top of perimeter trims and avoid concrete heaping. Cylinder strength shall not be less than **4.35 ksi**, with a maximum aggregate size of **0.75 in.**



UNDERSIDE VIEW

The installed ribbed ceiling provides suitable substrate for direct finishing; applying additional fire safety protection; enhanced acoustical treatment and finishing with a variety of finished ceiling materials.





CONSTRUCTION AND INSTALLATION GUIDELINES

EXAMPLES OF CONSTRUCTION APPLICATIONS

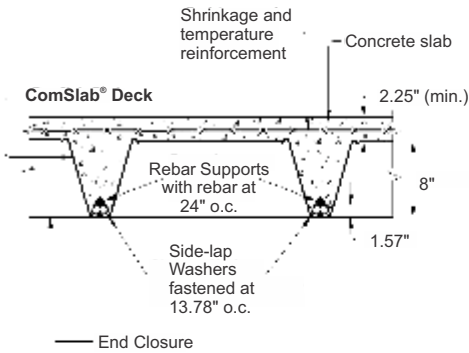

END CLOSURE DETAIL

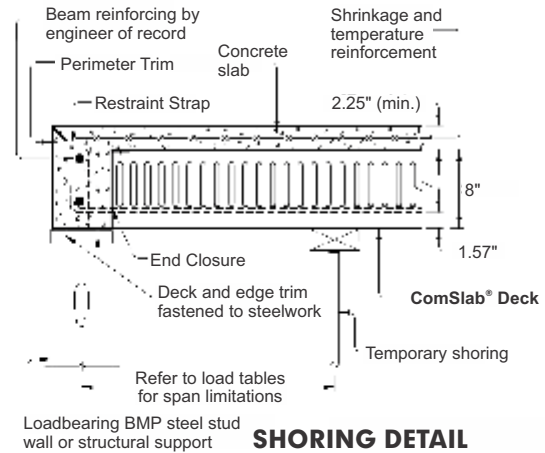

SHORING DETAIL

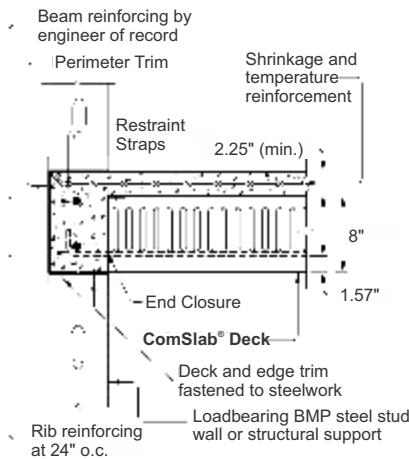

END BEARING DETAIL

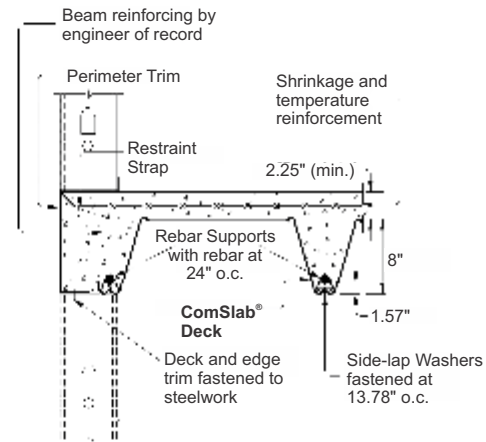

PERIMETER BEARING DETAIL

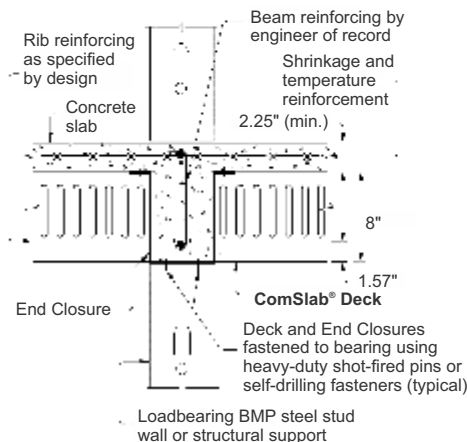

WALL CONNECTION DETAIL

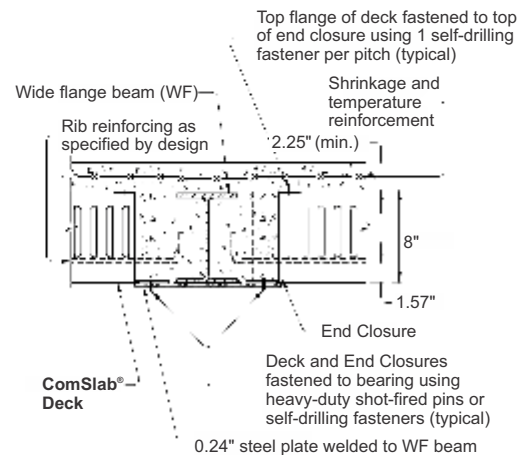

WIDE FLANGE BEAM DETAIL

NOTE: The following examples of construction applications for ComSlab® are illustrative only and should only be used with the final approval of the engineer of record.



CONSTRUCTION AND INSTALLATION GUIDELINES

EXAMPLES OF CONSTRUCTION APPLICATIONS

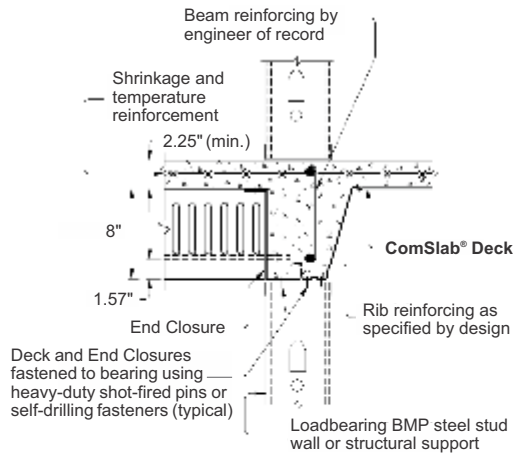

PANEL DIRECTION CHANGE DETAIL

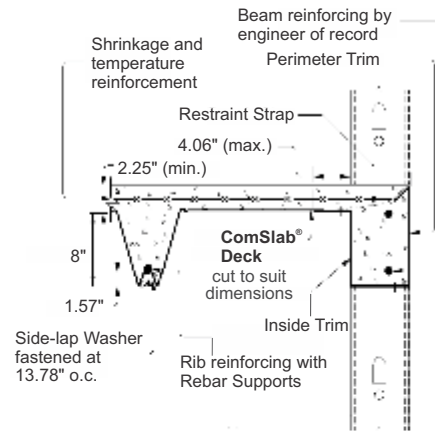

SIDE PERIMETER BEARING DETAIL

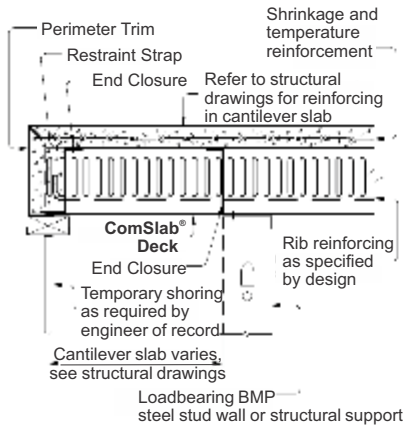

END CANTILEVER DETAIL

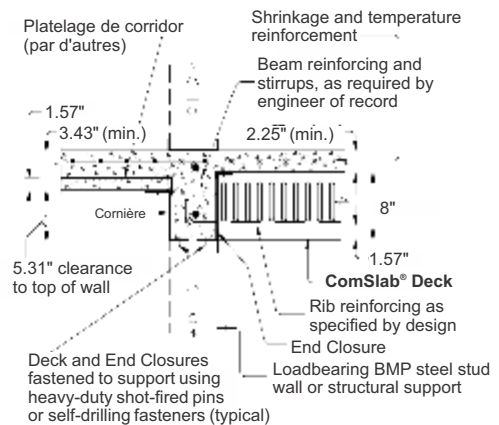

CORRIDOR BEARING DETAIL

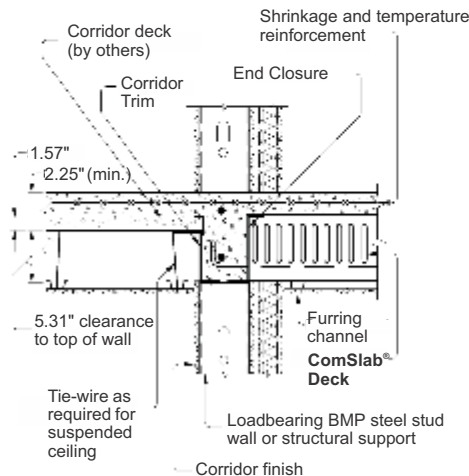

CORRIDOR FINISHING DETAIL

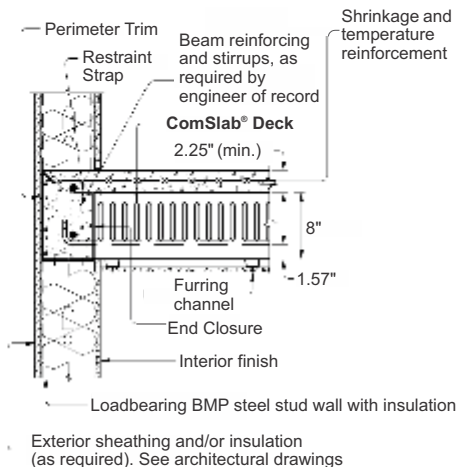

END BEARING FINISHING DETAIL

NOTE: The following examples of construction applications for ComSlab® are illustrative only and should only be used with the final approval of the engineer of record.



CONSTRUCTION AND INSTALLATION GUIDELINES

EXAMPLES OF CONSTRUCTION APPLICATIONS

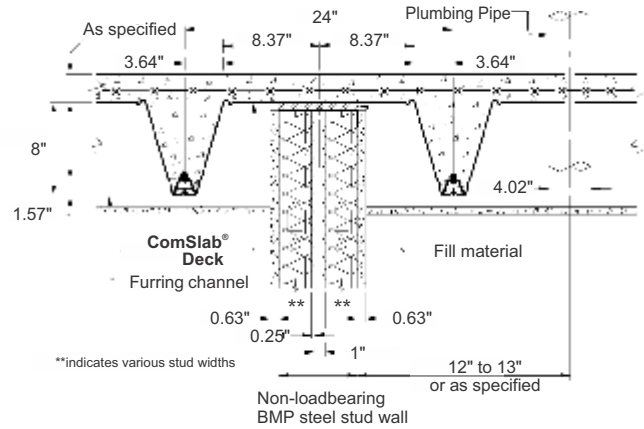
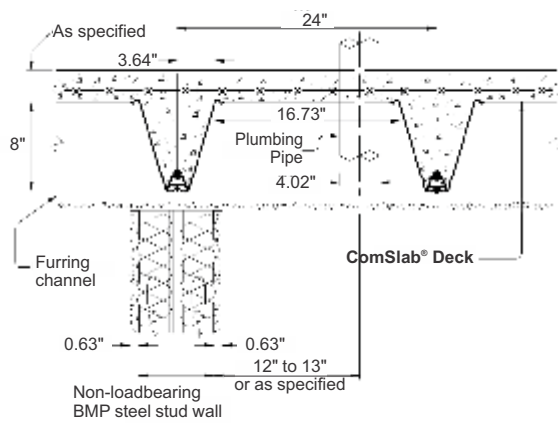

SUGGESTED CLEARANCE NEAR PLUMBING STACKS

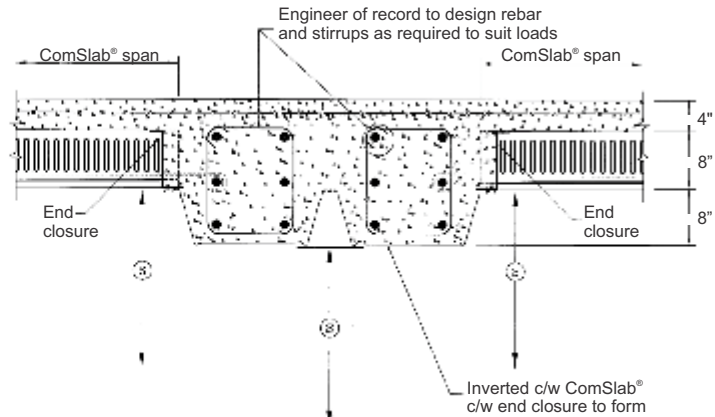
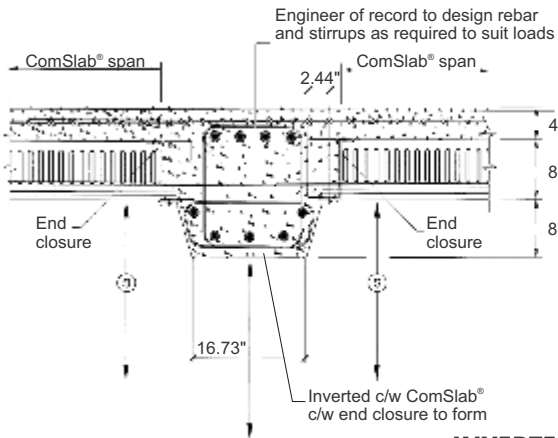

INVERTED ComSlab® - BEARING BEAM

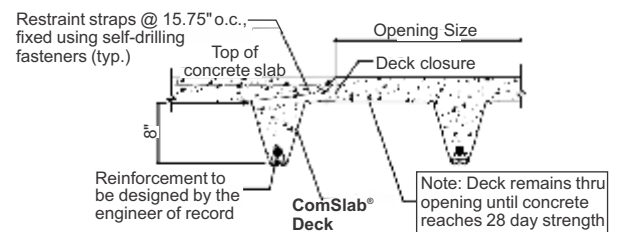
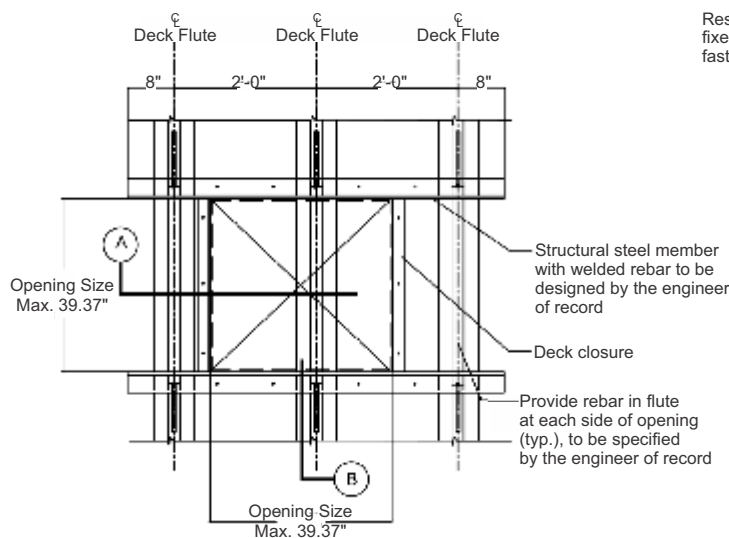

Ⓐ OPENING PERPENDICULAR TO DECK SPAN DETAIL



Ⓑ OPENING PERPENDICULAR TO DECK SPAN DETAIL

ComSlab® CUT-THROUGH RIB REBAR DETAIL OPENING

NOTE: The following examples of construction applications for ComSlab® are illustrative only and should only be used with the final approval of the engineer of record.



ComSlab® DETAILS

ComSlab® FIRE RATINGS

FIRE SAFETY PERFORMANCE TESTS

Unprotected Fire Rated Assemblies

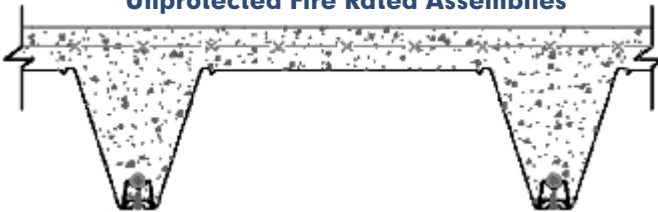

Protected Fire Rated Assemblies

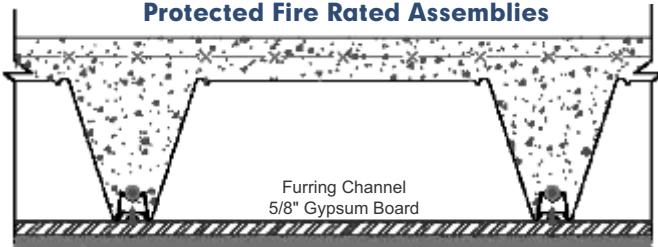

Design No.	Rating HR*	Min. Concrete Topping
UL D930	1.0	2.50 in.
	1.5	3.50 in.
	2.0	4.50 in. (NWC**)/3.25 in. (LWC**) [†]

[†] Please contact Bailey Metal Products Limited for custom load table data pertaining to this design condition.

** NWC is normal weight concrete and LWC is lightweight concrete.

Design No.	Rating HR*	Min. Concrete Topping
UL D504	2.0	3.50 in.

* Valid for both restrained condition (no span limitation) and unrestrained condition (up to 32'10").

ACOUSTICAL PERFORMANCE

ACOUSTICAL PERFORMANCE - TESTED ASSEMBLIES WITH STC & IIC RATINGS

Tested Assembly	Concrete Topping (in.)	Total Slab Thickness (in.)	Assembly Depth (in.)	Result
<ul style="list-style-type: none"> 2-1/2" Concrete topping ComSlab® 8" deck 	2.5	10.5	10.5	STC 47
<ul style="list-style-type: none"> 2-1/2" Concrete topping ComSlab® 8" deck 	2.5	10.5	12.0	STC 56
<ul style="list-style-type: none"> 2-1/2" Concrete topping ComSlab® 8" deck 	2.5	10.5	11.625	STC 58
<ul style="list-style-type: none"> Tile with grout & cement 4 mm "Quiet Down - Rubber Pad" 8 mm "Soft Step - Rubber Pad" 2-1/2" Concrete topping ComSlab® 8" deck 	2.5	10.5	12.0 + (1.0 estimated floor finish)	STC 60
<ul style="list-style-type: none"> Tile with grout & cement 4 mm "Quiet Down - Rubber Pad" 8 mm "Soft Step - Rubber Pad" 2-1/2" Concrete topping ComSlab® 8" deck 	2.5	10.5	12.0 + (1.0 estimated floor finish)	IIC 54
<ul style="list-style-type: none"> Carpet with under pad 2-1/2" Concrete topping ComSlab® 8" deck 	2.5	10.5	12.0 + (floor finish)	IIC 60
<ul style="list-style-type: none"> Carpet with under pad 2-1/2" Concrete topping ComSlab® 8" deck 	2.5	10.5	11.625 + (floor finish)	IIC 68

TABLE NOTES: Acoustical performance was tested for both Sound Transmission Class (STC) and Impact Insulation Class (IIC). The methods and procedures used in these testings were conducted in accordance to the provisions and requirements of **ASTM E 90 - 04 / E 413 - 04** and **ASTM E 492 - 04 / E 989 - 06**.



ComSlab® DETAILS

TYPICAL ComSlab® ROUND SERVICE HOLE DETAILS

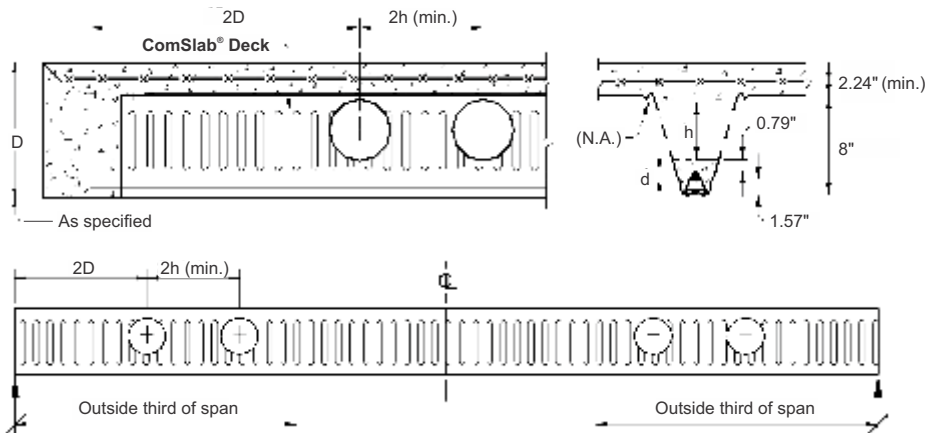

NOTATIONS:

D = Overall Slab Depth
d = Rebar diameter
h = Maximum hole diameter
N.A. = Neutral Axis

ComSlab® MAXIMUM HORIZONTAL OPENING TABLE

Maximum Hole Diameter	Nominal Bar Designation								
	#3	#4	#5	#6	#7	#8	#9	#10	#11
h (in.)	4.88	4.76	4.61	4.45	4.29	4.13	3.98	3.82	3.66

ComSlab® CONCRETE VOLUME VALUES FOR ESTIMATING

IMPERIAL UNITS	Slab Thickness (in.)	10.5	11.0	11.5	12.0	12.5	13.0	13.5	14.0
		Concrete Volume (yd ³ /100 ft ²)	1.26	1.42	1.57	1.72	1.88	2.03	2.19

REINFORCING BAR INFORMATION

Nominal Bar Designation	Actual Values		Mass per Unit Length lb/ft.
	Diameter in.	Area in. ²	
#3	0.375	0.11	0.376
#4	0.500	0.20	0.668
#5	0.625	0.31	1.043
#6	0.750	0.44	1.502
#7	0.875	0.60	2.044
#8	1.000	0.79	2.670
#9	1.128	1.00	3.400
#10	1.270	1.27	4.303
#11	1.410	1.56	5.313

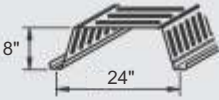
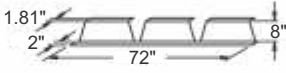

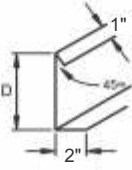
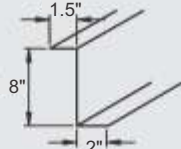
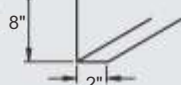
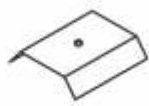

TABLE NOTES

- 0.787 in. (20 mm) of concrete is required above each rebar.
- Clear distance from the bottom of each rebar is 1.57 in. (40 mm) minimum.
- The spacing between any two holes shall not be less than 2h.
- No more than 2 holes shall be placed side by side, with the end distance spacing not less than 2D.
- Hole(s) shall be positioned in the outside thirds of span, as shown above.



ComSlab® DETAILS

ComSlab® STEEL DECK AND ACCESSORIES

MATERIALS	THICKNESS	WEIGHT	PACKAGING
	inches		Pieces
ComSlab® STEEL DECK (G90 FINISH) 	0.0375	2.58 lb/ft ²	30 pieces per bundle cut to length
	0.0495	3.41 lb/ft ²	
90° END CLOSURES (G90 FINISH) 	0.054	1.75 lb/ft. or 10.5 lb/pc	50 pieces per bundle
45° END CLOSURES (G90 FINISH) 	0.054	1.71 lb/ft. or 14.5 lb/pc	50 pieces per bundle
PERIMETER TRIMS (G90 FINISH)  <p>D = overall slab depth</p>	0.054	39 lb/pc to 45 lb/pc	10 pieces per bundle 10 ft. lengths
INSIDE TRIMS (G60 FINISH) 	0.033 0.043	20 lb/pc 25 lb/pc	10 pieces per bundle 10 ft. lengths
CORRIDOR TRIMS (G60 FINISH) 	0.054	30 lb/pc	
SIDE-LAP WASHERS (G60 FINISH) 	0.043	25 lb per carton	500 pieces per carton
REBAR SUPPORTS (G60 FINISH) 	0.033	45 lb per carton	300 pieces per carton
RESTRAINT STRAPS (G60 FINISH) 	0.033	10 lb per bundle	50 pieces per bundle
FASTENERS No.14 1/4 - 14 X 1" Hex S.D. Zinc		4 lb per carton	300 pieces per carton
SCREWS No.8 x 1/2" Wafer S.D. Zinc		4 lb per carton	1500 pieces per carton



ComSlab® PROJECTS



Hospitality - The Ritz Carlton, Aruba, Dutch Caribbean



Mixed Use - 1900 Arch Street, Philadelphia, USA



Southdale Condominium
London, Canada



The Watermark
Toronto, Canada

High Rise
& Low Rise
Residential



Retirement Residence
Stouffville, Canada



Retirement Residence
Newmarket, Canada

BAILEY METAL PRODUCTS LIMITED

For more information, please contact us at:

1-800-668-2154 ♦ www.comslab.ca ♦ www.comslab-usa.com

www.comslab-usa.com