



BXUV.D902

Design/System/Construction/Assembly Usage Disclaimer

- Authorities Having Jurisdiction should be consulted in all cases as to the particular requirements covering the installation and use of UL Certified products, equipment, system, devices, and materials.
- Authorities Having Jurisdiction should be consulted before construction.
- Fire resistance assemblies and products are developed by the design submitter and have been investigated by UL for compliance with applicable requirements. The published information cannot always address every construction nuance encountered in the field.
- When field issues arise, it is recommended the first contact for assistance be the technical service staff provided by the product manufacturer noted for the design. Users of fire resistance assemblies are advised to consult the general Guide Information for each product category and each group of assemblies. The Guide Information includes specifics concerning alternate materials and alternate methods of construction.
- Only products which bear UL's Mark are considered Certified.

BXUV - Fire Resistance Ratings - ANSI/UL 263 Certified for
United States

BXUV7 - Fire Resistance Ratings - CAN/ULC-S101 Certified for
Canada

See General Information for Fire-resistance Ratings - ANSI/UL 263 Certified for United States
Design Criteria and Allowable Variances

See General Information for Fire Resistance Ratings - CAN/ULC-S101 Certified for Canada
Design Criteria and Allowable Variances

Design No. D902

April 01, 2020

Restrained Assembly Ratings — 1, 1-1/2, 2 and 3 Hr.

Unrestrained Assembly Ratings — 0, 1, 1-1/2, 2 or 3 Hr. (See Items 4 & 6)

Unrestrained Beam Ratings — 1, 1-1/2, 2 and 3 Hr.

This design was evaluated using a load design method other than the Limit States Design Method (e.g., Working Stress Design Method). For jurisdictions employing the Limit States Design Method, such as Canada, a load restriction factor shall be used — See Guide BXUV or BXUV7

*** Indicates such products shall bear the UL or cUL Certification Mark for jurisdictions employing the UL or cUL Certification (such as Canada), respectively.**

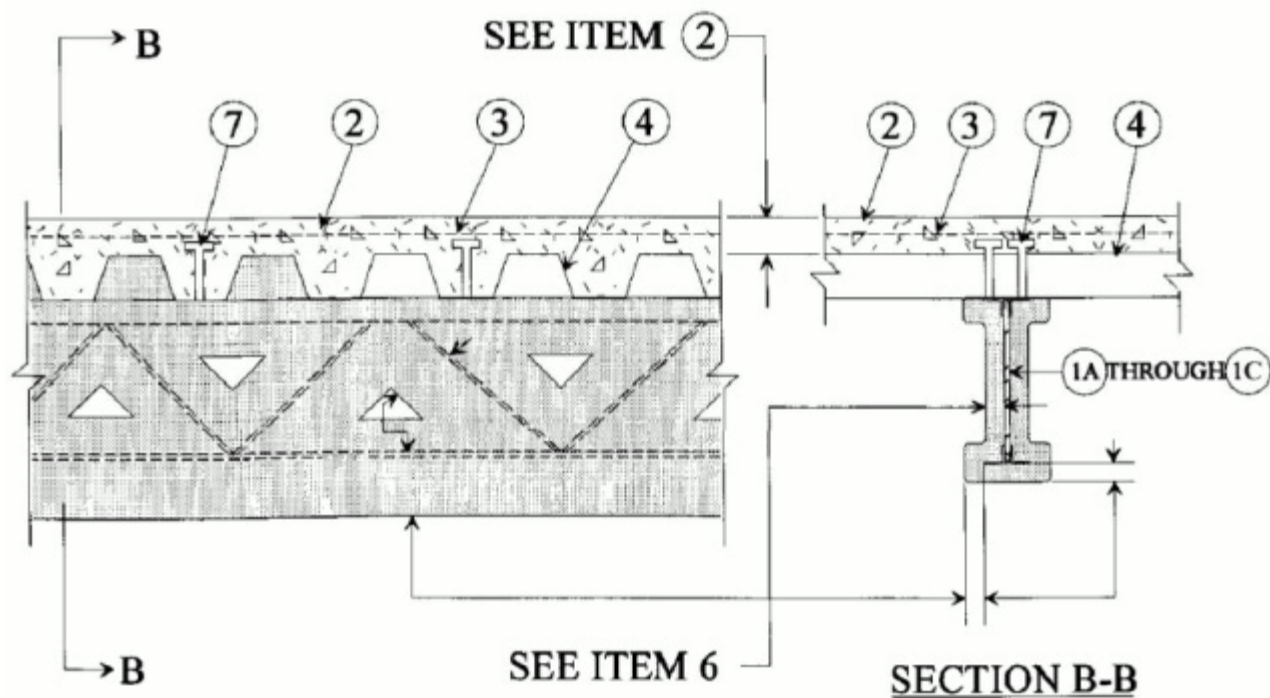
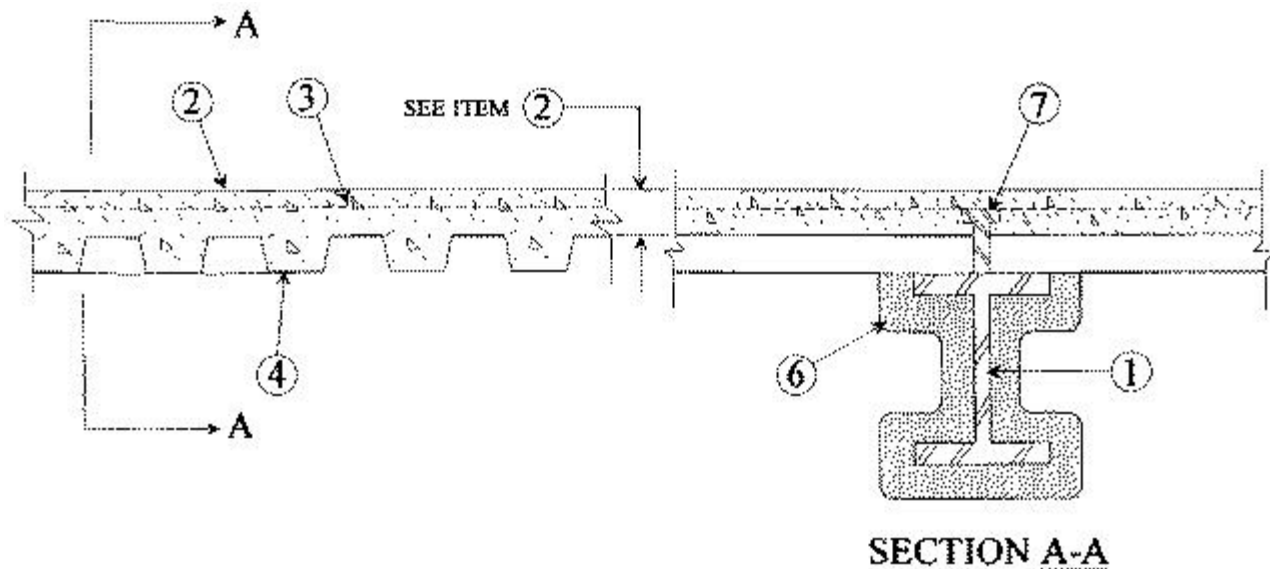

1. **Beam** — W8X28, W8x24, W6x12 or W6x9, min size, see Items 6 through 6F.

1A. **Steel Joists** — (Not Shown) — As an alternate to Item 1 — Composite or non-composite min 8k1 or min depth and weight shall be 8 in. and 4.9 lb/ft respectively. May be uncoated or provided with a shop coat of paint. Designed per S.J.I. specifications for a max design stress of 30, 000 psi (30 ksi). Welded or bolted to end supports. The top chords shall consist of two angles measuring 1-1/4 by 1-1/4 by 0.127 in. thick. Bottom chords shall consist of two round bars measuring 0.566 in. in diam. or two angles measuring 1 by 1 by 0.125 in. thick. Bearing plates shall consist of two angles measuring 1-1/2 by 2 by 0.188 in. thick and 5-1/16 in. long. Web members shall consist of 0.565 in. diam bars.

1B. **Steel Joists** — (Not Shown) — As an alternate to Item 1 — Composite or non-composite min 12k5 or min depth and weight shall be 12 in. and 7.1 lb/ft respectively. May be uncoated or provided with a shop coat of paint. Designed per S.J.I. specifications for a max design stress of 30, 000 psi (30 ksi). Welded or bolted to end supports. Top chords shall consist of two angles measuring 1-1/2 by 1-1/2 by 0.156 in. thick. Bottom chords shall consist of two round bars measuring 0.675 in. in diam. or two angles measuring 1 by 1 by 0.125 in. thick. Bearing plates shall consist of two angles measuring 2 by 2 by 0.192 in. thick and shall be min 4-15/16 in long. The second web member at each end shall consist of 0.654 in. diam round bar. All remaining web members, including the end web members,

shall consist of 0.774 in. diam round bars. Bridging per S.J.I. specifications is required when non-composite joists are used.

1C. **Steel Joists** — (Not Shown) — As an alternate to Item 1 — Composite or non-composite min 12k5 or min depth and weight shall be 12 in. and 7.1 lb/ft respectively. May be uncoated or provided with a shop coat of paint. Designed per S.J.I. specifications for a max design stress of 30, 000 psi (30 ksi). Welded or bolted to end supports. Top chords shall consist of two angles measuring 1-1/2 by 1-1/2 by 0.156 in. thick. Bottom chord shall consist of two round bars measuring 0.675 in. in diam. or two nangles measuring 1 by 1 by 0.125 in. thick. The second web member at each end shall consist of 0.654 in. diam round bar. All remaining web members, including the end web members, shall consist of 0.774 in. diam round bars. Bridging per S.J.I. specifications is required when non-composite joists are used.

Note: Additional beams or joists from the N series designs may be substituted for the listed beam (item 1) or joist (item 1A) respectively. When joists are substituted, the restrained rating of the joist must be equal to or greater than the restrained rating of the assembly. Additional beam and joist substitution requirements are in the front of the Fire Resistance Directory - III. FLOOR-CEILINGS AND ROOF-CEILING, item 7 -Steel Joist or IV. BEAMS.

2. **Normal Weight or Light Weight Concrete** — Normal weight concrete, carbonate or siliceous aggregate, 3500 psi compressive strength, vibrated. Light weight concrete, expanded shale or slate aggregate by rotary-kiln method or expanded clay aggregate by rotary-kiln or sintered-grate method, or pelletized expanded blast furnace slag aggregate, 3000 psi compressive strength, vibrated, 4 to 7 per cent entrained air.

Restrained Assembly Rating Hr	Concrete (Type)	Concrete Unit Weight pcf	Concrete Thkns In.
1	Normal Weight	147-153	3-1/2
1-1/2	Normal Weight	147-153	4
2	Normal Weight	147-153	4-1/2
3	Normal Weight	147-153	5-1/4
1	Light Weight	107-113	2-1/2
1	Light Weight	107-120	2-5/8
1-1/2	Light Weight	107-113	3
2	Light Weight	107-113	3-1/4
2	Light Weight	107-116	3-1/4*
2	Light Weight	114-120	3-1/2
3	Light Weight	107-113	4-3/16
3	Light Weight	114-120	4-7/16

* With 2 and 3 in. deep steel floor units only.

3. **Welded Wire Fabric** — 6x6 - W1.4xW1.4.

3A. **Negative Reinforcement** — (Optional, Not Shown) Used in lieu of Item 3 and with Items 3B or 3C. For floor spans with concrete cast continuous over the supporting beams. Deformed bars designed to resist the support moments of the concrete slab in accordance with the latest ACI Building Code Specifications.

3B. **Fiber Reinforcement*** — (Not Shown) — Required with Item 3A. Engineered synthetic fibers added to concrete mix to control shrinkage cracks in concrete. Fibers added to concrete mix at rate of 1 lb of fiber for each cubic yard

of concrete.

PROPEX OPERATING COMPANY L L C — Fibermesh 150 and Fibermesh 300.

3C. Fiber Reinforcement* — (Not Shown) — Required with Item 3A. Any fiber reinforcement bearing the UL Classification Marking for Fire Resistance, Classified for use in lieu of welded wire fabric.

See **Fiber Reinforcement** (CBXQ) Category for names of manufacturers.

4. Steel Floor and Form Units* — Composite 1-1/2, 1-5/8, 2 or 3 in. deep galv units or 4-1/2 in. deep non-composite galv units. Fluted units may be phos/ptd. Min gauges are 22 MSG for fluted and 20/20 for cellular and partial cellular units. The following combinations of units may be used:

(1) All 24, 26, 28 or 36 in. wide cellular or partial cellular.

(2) All fluted.

(3) One or two 3 in. deep, 12 in. wide, 18/18 MSG min cellular alternating with 3 in. deep fluted or other cellular.

(4) Any blend of fluted and 24, 26, 28 or 36 in. wide cellular or partial cellular.

(5) Corrugated, nom 1-5/16 or 2 in. deep, 30 in. wide, 24 MSG min galv units with shear wires factory welded to deck corrugations. Welded to supports 12 in. OC through welding washers. For shear wire spacing of 8 in. or less the steel deck stress shall not exceed 20 KSI. For shear wire spacing greater than 8 in. OC but less than or equal to 12 in. OC steel deck stress shall not exceed 12 KSI.

ASC STEEL DECK, DIV OF ASC PROFILES L L C — 32 in. wide Types NH-32, NHN-32, NHF-32; 36 in. wide, Types BH-36, BHN-36, BHN-35-1/4, BHF-36, BHF-36A, 2WH-36, 2WHS-36, 2WHF-36, 2WHF-36A, 3WxH-36, 3WxHF-36, 3WxHF-36A, 3WH-36, 3WHF-36, 3WHF-36A, 3W-36, 3WF-36, DG3W-36, DG3WF-36. All units may be galvanized or Prime Shield. Non-cellular decks may be vented designated with a "V" suffix to the product name. Cellular deck top and bottom sections may be riveted together (designated with "Fr") vs. arc spot welded, "F"

CANAM STEEL CORP — 24 in. wide Type P-2432 composite or 36 in. wide Type P-3623, P-3606, P-3615 and 24 in wide Type P-2432 composite, Type P-3606 and P-3615 non-composite

CANAM STEEL CORP — 12 or 24 in. wide, Types 1-1/2, 2, or 3 in. LOK-Floor and LOK-Floor Cell; 36 in. wide, Types 2 or 3 in. LOK-Floor and LOK-Floor Cell; 24, 30 or 36 in. wide, Type 1-1/2 in. B-LOK and B-LOK Cell; 24 in. wide, Types N-LOK and N-LOK Cell

CENTRIA, A DIVISION OF NCI GROUP, INC — QL Types, 24 in. wide, 3 or 3 inverted, UKX, 21 or 21 inverted, 2 in. 99, 121, AKX, NKX, TKX; 24 or 30 in. wide GKX, GKXH, GKX-A; 36 in. wide 2 in. 99, AKX, WKX; 12 in. wide NKC, TKC; 12 in. wide non-composite Sec 12. Side joints of 99, 121, TKC, TKX, WKX may be welded together 60 in. OC. Side joints of 99, AKX, WKX, GKX, GKX-A, TKX may be fastened together with min 1 in. long No. 12x14 self-drilling, self-tapping steel screws 36 in. OC

CHIA TEH CONSTRUCTION MATERIAL CO LTD — 24 or 36 in. wide Mac-Lok 3; 24 in. wide CFD-3

DECK WEST INC — 36 in. wide Type B-DW, Inverted B-DW, BA-DW, Inverted BA-DW, 2-DW or 3-DW. Side joints of Type 2-DW and 3-DW may be fastened together with min 1 in. long No. 12 x 14 self-drilling, self-tapping steel screws 36 in. OC

DESIGN ASSISTANCE CONSTRUCTION SYSTEMS INC — 36 in. wide Type DACS1.5CD, or 24 in. wide Type DACS2.0CD, or DACS3.0CD

EPIC METALS CORP — 24 in. wide Types EC150, EC150 inverted, EC300, EC366, ECP150, ECP300, ECP366, ECA; 30 in. wide Types ECB150, ECBR150; 36 in. wide Types EC156, EC266, ECP266

KAM INDUSTRIES LTD, DBA CORDECK — 24 in. wide, Types 2 or 3 in. WDR

MARLYN STEEL DECKS INC — Type 1.5 CF, 2.0 CF or 3.0 CF

NEW MILLENNIUM BUILDING SYSTEMS L L C — 24 or 36 in. wide Types 2.0CD, 3.0CD, 2.0CFD, 3.0CFD, 3.0CFDES; 24, 30 or 36 in. wide Types 1.5CD, 1.5CDI, 1.5CDR, 1.5CFD. Fluted units may be phos/painted or galvanized.

ROOF DECK INC — 36 in. wide Types LOK-1-1/2, LOK-1-1/2R; 24 in. wide Types LOK-2, LOK-3

STEEL MASTERS INTERNATIONAL DEPENDABLE STEEL — 36 in. wide Types 2WH-36, 3WH-36. Units may be phos/painted or galvanized.

VALLEY JOIST+DECK — 24 or 36 in. wide Types WVC 1-1/2 or WVC 2

VERCO DECKING INC - A NUCOR CO — FORMLOK™ deck types PLB, B, BR, PLN3, N3, PLN, N, PLW2, W2, PLW3, W3. Units are min 24 in. wide and may be galvanized, phos./ptd., or mill finish. Units may be cellular or acoustical cellular, with the suffix "CD" or "CD-AC" added to the product name, respectively. All non-cellular deck may be vented or non-vented. 12 in. wide PLW2, W2, PLW3 or W3 units may be blended with 24 or 36 in. wide PLW2, W2, PLW3 or W3 units, respectively; or Types PLN3-CD, N3-CD, PLN3, N3.

VULCRAFT, DIV OF NUCOR CORP — 24, 30 or 36 in. wide Types 1.5VL, 1.5VLI, 1.5PLVLI, 1.5VLP, 1.5VLR, 1.5PLVLP; 24 or 36 in. wide Types 1.5VLP, 1.5PLVLP, 2VLI, 2.0PLVLI, 2VLJ, 3VLI, 3.0PLVLI, 3VLJ, 2VLP, 2.0PLVLP, 3VLP, 3.0PLVLP, 2VLP, 2.0PLVLP, 3VLP, 3.0PLVLP. Types 1.5VL, 1.5VLI, 1.5PLVLI, 1.5VLR, 1.5VLP, 1.5PLVLP, 2VLI, 2.0PLVLI, 2VLJ, 3VLI, 3.0PLVLI, 3VLJ units may be phos/ptd. 24 or 36 in. wide Types 2VLJ, 3VLJ units ++ may be used for max 2 hr Restrained Assembly Rating. 36 in. wide Types 1.5 SB, 1.5 SBR; 24 or 36 in wide Types 2.0 SB, 3.0 SB, 36 in. wide Type High Strength 1.5 SBI, 36 in. wide Type High Strength 1.5 SBN; Units may be phos/ptd

Spacing of welds attaching units to supports shall be 12 in. OC for 12, 24, 36 in. wide units, four welds per sheet for 30 in. wide units. 6 in. OC for 18 in. wide and Sec. 12 units. Unless specified otherwise for specific units types, adjacent units button-punched or welded together 36 in. OC along side joints. For **3 Hr Rating**, units with overlapping type side joints welded together 24 in. OC max.

When a superimposed load of 250 PSF is desired the spacing of welds or button-punches shall not exceed 24 in. OC along side joints.

++ Side joints of Types 2VLJ or 3VLJ units may be fastened together with No. 8-3/4 in. long self-drilling Tek screws driven diagonally from the top side through the joint of the units at 36 in. O. C. max.

Alternate Construction — Non-composite units of the same type listed above may be used provided allowable loading is calculated on the basis of non-composite design.

The Unrestrained Assembly Rating is equal to the Unrestrained Beam Rating (See Item 6) for a max 3 Hr and is limited to the following units and limitations:

- (a) 1-1/2, 2 and 3 in. deep, 24 or 36 in. wide, 22 MSG or thicker fluted with clear spans not more than 7 ft, 8 in.
- (b) 1-1/2, 2 and 3 in. deep, 24 or 36 in. wide, 20 MSG or thicker fluted with clear spans not more than 8 ft, 8 in.
- (c) 1-1/2 and 2 in. deep, 24 or 36 in. wide, 16 MSG or thicker fluted and 18/18 MSG or thicker cellular with clear spans not more than 9 ft, 11 in.
- (d) 3 in. deep, 36 in. wide, 18 MSG or thicker fluted and 24 in. wide, 20/18 MSG or thicker cellular with clear spans not more than 13 ft, 2 in.

For assemblies utilizing 3-1/4 in. light weight concrete topping with a max Restrained Assembly Rating of 2 Hr, the Unrestrained Assembly Rating is equal to the Unrestrained Beam Rating (See Item 6) and is limited to the following

floor units and spans:

(a) 1-1/2, 2 and 3 in. deep, 24 or 36 in. wide, 22 MSG fluted and 20/20 MSG cellular with clear spans not more than 9 ft, 6 in.

(b) 2 and 3 in. deep, 24 or 36 in. wide, 20 MSG fluted and 20/20 MSG cellular with clear spans not more than 10 ft, 0 in.

(c) 3 in. deep, 24 in. wide, 20 MSG fluted and 20/20 MSG cellular with clear spans not more than 13 ft, 2 in.

4A. **Steel Floor and Form Units*** — As an alternate to Item 4, for use only when top of steel beam (Item 1) is filled solid with concrete for the full width of bearing from top of steel beam to top of concrete (Item 2):

BAILEY METAL PRODUCTS LTD — Type COMSLAB™ 210 and COMSLAB™ 225, Steel End Closure Flashing

5. **Joint Cover** — (Use with fluted units optional — Not Shown) — 2 in. wide cloth adhesive tape applied following the contour of the units.

6. **Spray-Applied Fire Resistive Materials*** — Applied by spraying with water to the final thicknesses shown below. When fluted steel deck is used and the fire protection thickness selected is based on all fluted deck, the area between the steel deck and the top flange of the steel beam shall be filled. When fluted steel deck is used and the steel beam is sprayed with the thicknesses applicable to cellular of blended units, the area between the steel deck and the top flange of the steel beam shall be plugged. Beam surfaces must be clean and free of dirt, loose scale, and oil. Min average density of 13 pcf with min. individual density of 11 pcf for Types II, II HS, or DC/F. Min average and min individual densities of 22 pcf and 19 pcf, respectively, for type HP. For method of density determination, refer to Design Information Section. The thickness of the Spray-Applied Fire Resistive Materials on the Structural Members (Item 1, 1A, or 1B) shall be as follows:

Min Thkns Spray Applied Resistive Mtl, In

Restrained Assembly Rating Hr	Unrestrained Beam Rating Hr	Concrete Type	W6x9 When Deck Is All Fluted	W6x9 When Deck Is Blend or All Cellular	W8x28 When Deck Is All Fluted	W8x28 When Deck Is Blend or All Cellular	Joist	Joist
							Item 1A When Deck Is Fluted Cellular or Blend	Item 1B When Deck Is Fluted Cellular or Blend
1	1	NW	9/16,15/16*	9/16, 1*	3/8,5/8*	3/8,11/16*	1+	—
1-1/2	1	NW	9/16,15/16*	9/16, 1*	3/8,5/8*	3/8,11/16*	1-9/16	—
2	1	NW	9/16,15/16*	9/16, 1*	3/8,5/8*	3/8,11/16*	2-1/16	—
2	2	NW	1-1/8	1-3/16	3/4	13/16	2-1/16	—
2	3	NW	1-3/4	1-7/8	1-3/16	1-5/16	—	3-1/4
3	1-1/2	NW	3/4	3/4	1/2	1/2	—	3-1/4
3	2	NW	1-1/8	1-3/16	3/4	13/16	—	3-1/4

3	3	NW	1-3/4	1-7/8	1-3/16	1-5/16	—	3-1/4
1	1	LW	9/16,15/16*	5/8, 1*	3/8,5/8*	7/16,11/16*	1-1/8+	—
1-1/2	1	LW	9/16,15/16*	5/8, 1*	3/8,5/8*	7/16,11/16*	1-3/4	—
2	1	LW	9/16,15/16*	5/8, 1*	3/8,5/8*	7/16,11/16*	2-1/4	—
2	2	LW	1-7/16	1-7/16	1	1	2-1/4	—
2	3	LW	2-1/4	2-5/16	1-9/16	1-5/8	—	3-1/4
3	1-1/2	LW	15/16	1	5/8	11/16	—	3-1/4
3	2	LW	1-7/16	1-7/16	1	1	—	3-1/4
3	3	LW	2-1/4	2-5/16	1-9/16	1-5/8	—	3-1/4

* This thickness applies when optional Item 12 or 13 are used over 3-1/4 in. light weight concrete topping.

** This thickness applies when optional Item 12 or 13 are used over 3-1/4 in. light weight concrete topping.

+ When bottom chords consist of 1 by 1 by 0.125 in. thick steel angles, the thickness of spray-applied fire resistive material shall be increased by 1/4 in. on the bottom chord only.

ISOLATEK INTERNATIONAL — Type D-C/F, HP, II or Type II HS. Investigated for exterior use. Type EBS or Type X adhesive/surface sealer optional.

6A. **Spray-Applied Fire Resistive Materials*** — Alternate to Item 6. See table below for appropriate thicknesses. When fluted steel deck is used and the fire protection thickness selected is based on all fluted deck, the area between the steel deck and the top flange of the steel beam shall be filled. When fluted steel deck is used and the steel beam is sprayed with the thicknesses applicable to cellular or blended units, the area between the steel deck and the top flange of the steel beam shall be plugged. Prepared by mixing with water and spray-applied in one or more coats to beam surfaces which must be clean and free of dirt, loose scale and oil. Min average density of 17.5 pcf with min individual value of 17.0 pcf. For method of density determination, see Design Information Section, Sprayed Material.

Min Thkns Applied Resistive Mtl, In					
Restrained Assembly Rating Hr	Unrestrained Beam Rating Hr	W6x9 When Deck Is All Fluted	W6x9 When Deck Is Blend or All Cellular	W8x28 When Deck Is All Fluted	W8x28 When Deck Is Blend or All Cellular
		1, 1-1/2, 2	1	1/2, 5/8*	1/2, 5/8*
2	2	1	1-3/16	11/16	13/16
2	3	1-9/16	1-7/8	1-1/16	1-5/16
3	1-1/2	3/4	13/16	1/2	9/16
3	2	1	1-3/16	11/16	13/16
3	3	1-9/16	1-7/8	1-1/16	1-5/16

* This thickness applies when optional Items 12, 13 are used over 3-1/4 in. light weight concrete topping.

ISOLATEK INTERNATIONAL — Type 280

6B. Spray-Applied Fire Resistive Materials* — Alternate to Items 6 and 6A. Prepared by mixing with water. Spray-applied in one or more coats to beam surfaces to a min final thickness as shown in the tables below. Beam surfaces must be clean and free of dirt, loose scale and oil. When fluted steel deck is used and the fire protection thickness selected is based on all fluted deck, the area between the steel deck and the top flange of the steel beam shall be filled. When fluted steel deck is used and the steel beam is sprayed with the thicknesses applicable to cellular or blended units, the area between the steel deck and the top flange of the steel beam shall be plugged.

Min average and min individual density of 15 pcf and 14 pcf respectively for Types 300, 300AC, 300 ES, 300 HS, 300 N, 3000, 3000ES, and SB. For Types 400, 400 AC and 400 ES min average and min individual density of 22 pcf and 19 pcf respectively. Min avg density of 44 pcf with min ind value of 40 pcf for Types M-II and TG. Min avg density of 47 pcf, with min individual value of 43 pcf for Type M-II/P. The thickness of the material on the Structural Members (Item 1 and 1C) shall be as follows:

Min Thkns Spray Applied Resistive Mtl, In

Restrained Assembly Rating Hr	Unrestrained Beam Rating Hr	W6x9 When Deck Is All Fluted	W6x9 When Deck Is Blend or Cellular	W8x28 When Deck Is All Fluted	Joist (Item 1C)	
					W8x28 When Deck Is Blend or All Cellular	When Deck Is Fluted Cellular or Blend
1	1	1/2 , 5/8*	1/2 , 5/8*	5/16, 7/16*	5/16, 7/16*	9/16+
1-1/2	1	1/2 , 5/8*	1/2 , 5/8*	5/16, 7/16*	5/16, 7/16*	1
2	1	1/2 , 5/8*	1/2 , 5/8*	5/16, 7/16*	5/16, 7/16*	1-3/8
2	2	1	1-3/16	11/16	13/16	1-3/8
2	3	1-9/16	1-7/8	1-1/16	1-5/16	2-1/4
3	1-1/2	3/4	13/16	1/2	9/16	2-1/4
3	2	1	1-3/16	11/16	13/16	2-1/4
3	3	1-9/16	1-7/8	1-1/16	1-5/16	2-1/4

* This thickness applies when optional Item 12 or 13 are used over 3-1/4 in. light weight concrete topping.

+ When bottom chords consist of 1 in. by 1 in. by 0.125 in. thick steel angles, the thickness of spray-applied fire resistive material shall be increased by 1/4 in. on the bottom chord only.

BERLIN CO LTD — Types 300, 300ES, 300N, SB, or 400; Type M-II, TG and M-II/P

GREENTECH ASIA PACIFIC SDN BDH — Types 300, 300ES, 300HS, or 400; Type M-II, or M-II/P

GREENTECH THERMAL INSULATION PRODUCTS MFG CO L L C — Types 300, 300AC, 400, or 400AC; Type M-II, TG and M-II/P

ISOLATEK INTERNATIONAL — Types 300, 300AC 300ES, 300HS, 300N, SB, 400, 400AC, 400ES, 3000 or 3000ES; Type M-II, TG and M-II/P

NEWKEM PRODUCTS CORP — Types 300, 300ES, 300N, 400, or SB; Type M-II, TG and M-II/P

6C. Mastic and Intumescent Coatings* — As an alternate to Items 6 through 6B. For use with fluted steel floor and form units only. Min. size W8x24 or W6x12 beams shall be primed with a phenolic modified alkyd primer, a metal alkyd primer, an acrylic primer or an epoxy primer at a nominal thickness of 2 mil. Coating spray or brush applied in accordance with the manufacturer's instructions at the min dry thickness as shown in the table below. The thickness shown below includes the primer thickness. Flutes above beam to be completely filled with minimum 6 pcf mineral wool insulation, or the top flange of the beam to be protected with the same thickness of coating as required on the beam.

Minimum Dry Thickness mils	Minimum Dry Thickness mm	Beam Size	Unrestrained Beam Rating Hr	Restrained Assembly Rating Hr
53	1.34	W8x24	1	2
95	2.41	W8x24	1-1/2	3
73	1.83	W6x12	1	2
123	3.10	W6x12	1-1/2	3

BERLIN CO LTD — Type WB 3, Investigated for Interior General Purpose. Type WB 4, Investigated for Interior General Purpose. Type WB4, Investigated for Exterior Use with top coat as described in Item 6E

GREENTECH THERMAL INSULATION PRODUCTS MFG CO L L C — Type WB 3, Investigated for Interior General Purpose. Type WB 4, Investigated for Interior General Purpose. Type WB4, Investigated for Exterior Use with top coat as described in Item 6E

ISOLATEK INTERNATIONAL — Type SprayFilm-WB 3 and Type WB 3, Investigated for Interior General Purpose. Type SprayFilm-WB 4 and Type WB 4, Investigated for Interior General Purpose. Type SprayFilm-WB 4 and Type WB4, Investigated for Exterior Use with top coat as described in Item 6E

NEWKEM PRODUCTS CORP — Type WB 3, Investigated for Interior General Purpose. Type WB 4, Investigated for Interior General Purpose. Type WB4, Investigated for Exterior Use with top coat as described in Item 6E

6D. Mastic and Intumescent Coatings* — As an alternate to Items 6 through 6C. For use with normal weight concrete. Min. size W8x28 beams shall be primed with a phenolic modified alkyd primer a metal alkyd primer, an acrylic primer or an epoxy primer at a nominal thickness of 2 mil. Coating spray or brush applied in accordance with the manufacturer's instructions at the min dry thickness as shown in the table below. The thickness shown below includes the primer thickness. The top surface of the top flange where fluted units are used must be protected with the coating material at the same min dry thickness at a min distance of 1 in. (25 mm) inward from the flange tip on both sides of the beam. Mineral wool insulation optional above top surface of the beam.

Minimum Dry Thickness mils	Minimum Dry Thickness mm	Steel Floor Units	Unrestrained Beam Rating Hr	Restrained Assembly Rating Hr
103	2.62	Fluted or Cellular	1-1/2	2

179	4.55	Cellular	1-1/2	3
341	8.67	Cellular	2	3

BERLIN CO LTD — Type WB 3, Investigated for Interior General Purpose. Type WB 4, Investigated for Interior General Purpose. Type WB 4, Investigated for Exterior Use with top coat as described in Item 6E

GREENTECH THERMAL INSULATION PRODUCTS MFG CO L L C — Type WB 3, Investigated for Interior General Purpose. Type WB 4, Investigated for Interior General Purpose. Type WB 4, Investigated for Exterior Use with top coat as described in Item 6E

ISOLATEK INTERNATIONAL — Type SprayFilm-WB 3 and Type WB 3, Investigated for Interior General Purpose. Type SprayFilm-WB 4 and Type WB 4, Investigated for Interior General Purpose. Type SprayFilm-WB 4 and Type WB 4, Investigated for Exterior Use with top coat as described in Item 6E

NEWKEM PRODUCTS CORP — Type WB 3, Investigated for Interior General Purpose. Type WB 4, Investigated for Interior General Purpose. Type WB4, Investigated for Exterior Use with top coat as described in Item 6E

6E. **Top Coat** — Type SprayFilm — TOPSEAL and Type TOPSEAL required for Exterior Use, applied at a minimum dry thickness of 14 mils (0.34 mm) over the intumescent material.

See Classification information in the **Mastic and Intumescent Coating** (CDWZ) category, Isolatek International, for mixing requirements.

6F. **Mastic and Intumescent Coatings*** — As an alternate to Items 6 through 6D. For use with normal weight or light weight concrete and fluted steel floor and form units only. Min size W8x24 beams shall be primed with a phenolic modified alkyd primer at a thickness of 2 mils or a epoxy primer at a nominal thickness of 1 mil. Coating spray or brush applied in accordance with the manufacturer's instructions at the thicknesses shown below. The thickness includes the thickness of primer. The top surface of the top flange where fluted units are used must be protected with the coating material at the same min dry thickness or filled with nominal 4 pcf mineral wool.

Minimum Dry Thickness mils	Minimum Dry Thickness mm	Beam Size	Unrestrained Beam Rating Hr	Restrained Assembly Rating Hr
35	0.88	W8x24	1	2
66	1.68	W8x24	1-1/2	3

GREENTECH THERMAL INSULATION PRODUCTS MFG CO L L C — Type WB-5, Investigated for Interior General Purpose

ISOLATEK INTERNATIONAL — Type WB-5, Investigated for Interior General Purpose

NEWKEM PRODUCTS CORP — Type WB 5, Investigated for Interior Conditioned Space and Interior General Purpose.

6G. **Sprayed Fiber Insulation*** — (Optional, Not Shown) — Spray applied fiber insulation applied over Spray-Applied Fire Resistive Material (Item 6) on both steel floor and form units (Item 4) and supports (Item 1). Sprayed fiber insulation may be over Spray-Applied Fire Resistive Material (Item 6) according to the following tables:

Allowable Spray-Applied Fiber Insulation Thickness Over Beam

Installed SFRM

Thickness (in.)

on Beam

SFRM Density (pcf)

	13	15	17.5	22	22 (Type HP)	44	47
3/8	6-3/4	4	4-11/16	5-7/8	8	8	8
7/16	6-1/2	3-3/4	4-3/8	5-1/2	8	8	8
1/2	6-1/4	3-1/2	4-1/16	5-1/8	8	8	8
9/16	6-1/16	3-3/16	3-3/4	4-11/16	8	8	8
5/8	5-13/16	2-15/16	3-7/16	4-5/16	8	8	8
11/16	5-9/16	2-11/16	3-1/8	3-15/16	8	8	8
3/4	5-5/16	2-7/16	2-13/16	3-9/16	8	8	8
13/16	5-1/8	2-1/8	2-1/2	3-1/8	8	8	8
1	4-7/16	1-5/16	1-9/16	1-15/16	7-7/16	6-5/16	6-11/16
1-1/16	4-3/16	1-1/16	1-1/4	1-9/16	7-1/16	5-1/2	5-7/8
1-3/16	3-11/16	9/16	5/8	13/16	6-5/16	3-15/16	4-3/16
1-5/16	3-1/4	0	0	0	5-1/2	2-3/8	2-1/2
1-9/16	2-5/16	0	0	0	3-15/16	0	0
1-5/8	2-1/16	0	0	0	3-9/16	0	0

Allowable Spray-Applied Fiber Insulation Thickness Over Joist

Installed SFRM Thickness (in.)

on Joist

SFRM Density (pcf)

	13	15	22	22 (Type HP)	44	47
9/16	8	8	8	8	8	8
13/16	8	8	8	8	8	8
1	8	8	8	8	8	8
1-1/8	7-7/8	7-1/2	8	8	8	8
1-1/4	7-7/16	6-15/16	8	8	8	8
1-3/8	6-15/16	6-7/16	8	8	8	8
1-9/16	6-1/4	5-5/8	8	8	8	8
1-3/4	5-9/16	4-13/16	7-1/16	8	8	8

2-1/16	4-7/16	3-1/2	5-1/8	7-7/16	8	8
2-1/4	3-11/16	2-11/16	3-15/16	6-5/16	7-7/8	8
3-1/4	0	0	0	0	0	0

INTERNATIONAL CELLULOSE CORP — Type K13, URE-K, or Sonospray FC

7. **Shear Connector Studs** — (Optional) — Studs, 3/4 in. diam by 3 in. long, for 1-1/2 in. deep form units to 5-1/4 in. long for 3 in. deep form units, headed type or equivalent per AISC specifications. Welded to the top flange of the beam through the steel form units.

8. **Lath Hanger** — (Optional, Not Shown) For use in caged beams with Items 6, 6A or 6B Galv steel 6 SWG min diam spaced 27 in. O. C.

9. **Clips** — (Optional, Not Shown) For use in caged beams with Items 6, 6A or 6B No. 24 MSG spring steel pushed on to top and bottom flanges of beam spaced 6 in. O. C. max.

10. **Metal Lath** — (Optional, Not Shown) — For use in caged beams with Items 6, 6A or 6B 3/8 in. diamond mesh or rib lath, 3.4 lbs per sq yd expanded steel attached to beam with clips spaced 6 in. OC max; or tied to lath hangers with 18 SWG galv steel wire spaced 6 in. OC max.

11. **Electrical Inserts*** — (Not Shown) — Classified as "Outlet Boxes and Fittings Classified for Fire Resistance".

12. **Mineral and Fiberboards*** — (Optional, Not Shown) — Applied over concrete floor with no restriction on board thickness. When mineral and fiber boards are used, the unrestrained beam rating shall be increased by a minimum of 1/2 hr.

See **Mineral and Fiber Board** (CERZ) category for names of manufacturers.

13. **Foamed Plastic*** — (Optional, Not Shown) — Consisting of polyisocyanurate or urethane roof insulations. Applied over concrete floor with no restrictions on thickness. When polyisocyanurate or urethane insulation is used, the unrestrained beam rating shall be increased by a minimum of 1/2 hr.

See **Foamed Plastic** (CCVW) for list of manufacturers.

14. **Insulating Concrete** — (Optional, Not Shown) — Various types of insulating concrete prepared and applied as follows:

A. Vermiculite Concrete - Blend 6 to 8 cu ft of **Vermiculite Aggregate*** to 94 lb Portland cement and air entraining agent. Min thickness of 2 in. as measured to the top surface of the structural concrete or foamed plastic (Item 15) when it is used. See **Vermiculite Aggregate** (CJZZ) category for names of Classified companies.

B. Cellular **Concrete-Roof Topping Mixture*** - Concentrate mixed with water and Portland cement per manufacturer's specifications. Min. thickness of 2-in. as measured to the top surface of the structural concrete or foamed plastic (Item 15 and 15A) when used. Cast dry density and 28-day min compressive strength of 190 psi as determined with ASTM C495-66.

AERIX INDUSTRIES — Cast dry density of 37 (+ or -) 3.0 pcf

CELCORE INC — Type Celcore with cast dry density of 31 (+ or - 3.0) pcf or Type Celcore MF with cast dry density of 29 (+ or - 3.0) pcf

ELASTIZELL CORP OF AMERICA — Type II, with a cast dry density of 39 (+ or - 3.0) pcf

SIPLAST INC — Mix #1, Cast dry density of 32 (+ or -) 3 pcf

SIPLAST INC — Mix #2, Cast dry density of 36 (+ or -) 3 pcf

C. Cellular **Concrete-Roof Topping Mixture*** - Foam concentrate mixed with water, Portland cement and UL Classified Vermiculite Aggregate per manufacture's application instructions. Cast dry density of 33 (+ or -) 3 pcf and 28 day compressive strength of min 250 psi as determined in accordance with ASTM C495-86.

AERIX INDUSTRIES — Mix #3

ELASTIZELL CORP OF AMERICA — Type II. Mix #1 of cast dry density 39 (+ or -) 3.0 pcf, Mix #2 of cast dry density 40 (+ or -) 3.0 pcf, Mix #3 of cast dry density 47 (+ or -) 3.0 pcf

SIPLAST INC — Mix #3

D. Perlite Concrete - 6 cu ft of **Perlite Aggregate*** to 94 lb of Portland Cement and 1-1/2 pt air entraining agent. Min thickness 2 in. as measured to the top surface of structural concrete or foamed plastic (Item 15A) when it is used.

See **Perlite Aggregate** (CFFX) in Fire Resistance Directory for names of Classified companies.

15. **Foamed Plastic*** — (Optional, Not Shown) — For use only with vermiculite (Item 14A) or cellular (Item 14B) concretes-Rigid polystyrene foamed plastic insulation having slots and/or holes sandwiched between vermiculite concrete slurry which is applied to the normal or light weight concrete surface and vermiculite concrete topping (Item 14A).

See **Foamed Plastic*** (BRYX) category in Building Materials Directory or **Foamed Plastic*** (CCVW) Category in Fire Resistance Directory for list of Classified companies.

15A. **Foamed Plastic*** — (Not Shown) — For use only with cellular or perlite concrete. Nominal 24 by 48 in. polystyrene foamed plastic insulation boards having a density of 1.0 (+ or - 0.1) pcf, encapsulated within concrete topping. Each insulation board shall contain six nominal 3 in. diameter holes oriented in two rows of three holes each with the holes spaced 12 in. OC transversely and 16 in. OC longitudinally.

See **Foamed Plastic*** (BRYX) category in Building Materials Directory or Foamed Plastic* (CCYW) category in Fire Resistance Directory for list of Classified companies.

16. **Roof Covering Materials*** — (Optional, Not Shown) — Consisting of materials compatible with insulations described herein which provide Class A, B or C coverings.

See Built-Up Roof Covering Materials in Building Materials Directory.

17. **Insulated Concrete** — (Optional, Not Shown) — various types of insulated concrete prepared and applied in the thickness indicated.

A. **Vermiculite Concrete** — Mix consists of 6 cu ft of Vermiculite Aggregate*, 94 lbs of Portland cement and 6 ox of air entraining agent. Thickness to be 2 in min from the top plane of steel roof deck.

ELASTIZELL CORP OF AMERICA — Types MS16-U, MSV 200.

B. **Perlite Concrete** — Mix consists of 6.2 cu ft **Perlite Aggregate*** to 94 lbs of Portland cement and 1-1/2 pt air entraining agent. Compressive strength 80 psi min.

See **Perlite Aggregate** (CFFX) category for names of Classified companies.

18. **Wall and Partition Facings and Accessories** — (Optional, Not Shown) Sound barrier for use with items 19 and 20: Acoustic Sleeper Pads stapled or adhered to the underside of the subflooring panels spaced 24 in. OC.

STC ARCHITECTURAL PRODUCTS L L C DBA STC SOUND CONTROL — Acoustic Sleeper

19. **Structural Cement Fiber Units*** — (Optional, Not Shown) - (For use with item 18) - Min 3/4 in. thick tongue and groove non-combustible structural cement fiber board loosely laid over concrete.

ECTEK INTERNATIONAL INC — Armoroc Panel

UNITED STATES GYPSUM CO — USG Structural Panel

EASI BUILDING PRODUCTS, INC. — Versaroc

20. **Building Units*** — (Optional, Not Shown) - (For use with item 18) - Panels loosely laid over concrete.

DRAGONBOARD USA L L C — Type DragonBoard, DragonBoard Flooring

EXTREMEGREEN BUILDING PRODUCTS LLC — Type 3/4 in. Shiplap Edge Extremegreen™ Board, 5/8 in. Tapered Edge Extremegreen™ Board, 1/2 in. Tapered Edge Extremegreen™ Board.

*** Indicates such products shall bear the UL or cUL Certification Mark for jurisdictions employing the UL or cUL Certification (such as Canada), respectively.**

Last Updated on 2020-04-01

The appearance of a company's name or product in this database does not in itself assure that products so identified have been manufactured under UL's Follow-Up Service. Only those products bearing the UL Mark should be considered to be Certified and covered under UL's Follow-Up Service. Always look for the Mark on the product.

UL permits the reproduction of the material contained in the Online Certification Directory subject to the following conditions: 1. The Guide Information, Assemblies, Constructions, Designs, Systems, and/or Certifications (files) must be presented in their entirety and in a non-misleading manner, without any manipulation of the data (or drawings). 2. The statement "Reprinted from the Online Certifications Directory with permission from UL" must appear adjacent to the extracted material. In addition, the reprinted material must include a copyright notice in the following format: "© 2020 UL LLC"