

LIGHTWEIGHT STEEL FRAMING DETAILS GENERAL & WIND BEARING



MONTREAL • TORONTO • CALGARY • EDMONTON • VANCOUVER



BAILEY[®]
METAL PRODUCTS LIMITED

WALL ELEVATIONS

Bailey Wind Bearing Walls (BWB) Lightweight Steel Framing (LSF) provides economical structural support for finishes under lateral wind loads on buildings where other structural components carry axial loads. BWB walls can be designed for a variety of deflection limits for finishes such as EIFS, Stucco, Metal Panel and Brick Veneer. Wind-Bearing LSF may be used in buildings of any height.

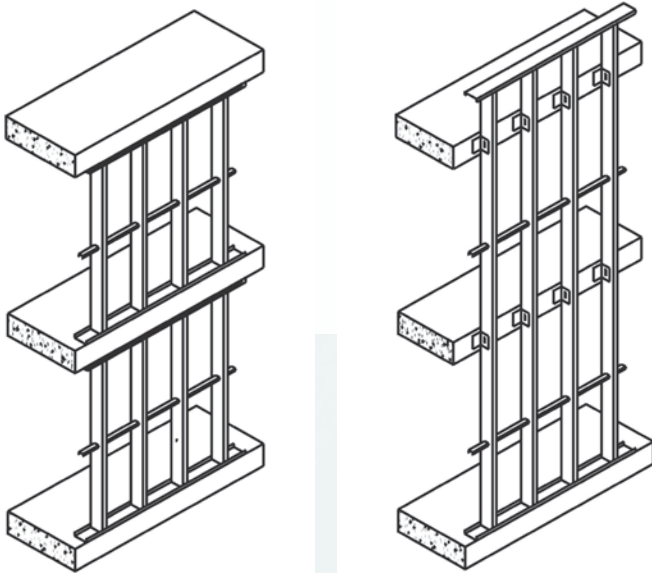

EXTERIOR INFILL WALLS /
CONTINUOUS EXTERIOR CURTAIN WALLS

Bailey Axial Loadbearing Walls (BAB) Lightweight Steel Framing (LSF) supports the combined axial and wind loads on interior and exterior walls. Buildings up to six stories in height can be framed using LSF. LSF works with a variety of floors including LSF Joists, ComSlab[®] composite flooring systems, OWSJ's and hollow precast concrete.

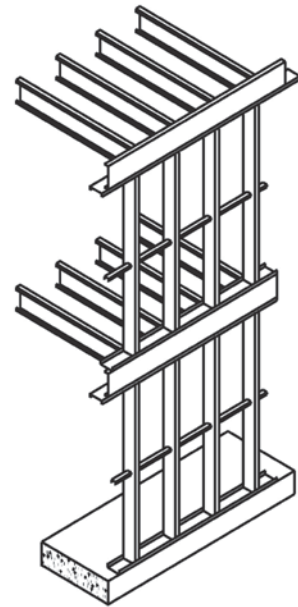

AXIAL LOAD BEARING WALLS

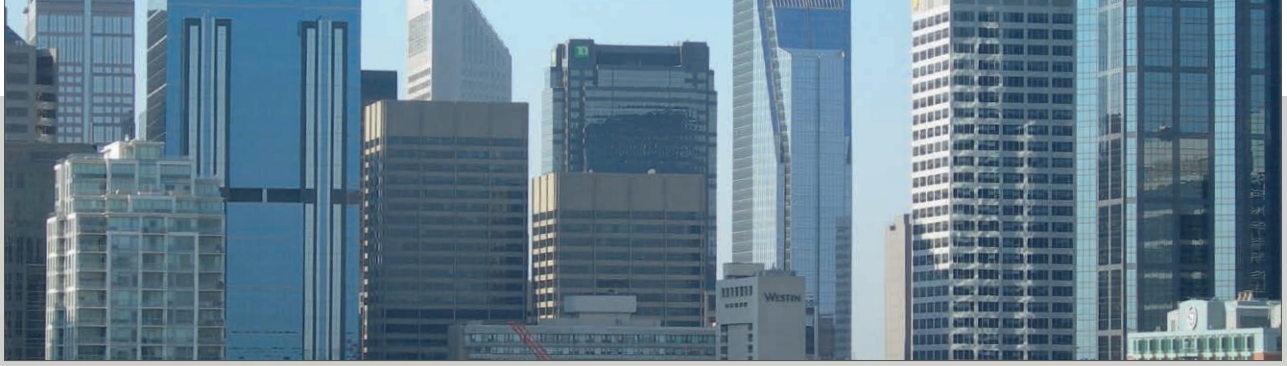

Bailey Joists for Floors & Roofs

Lightweight Steel Framing (LSF) Joists offer a wide range of span and load capabilities for commercial and residential floor systems and mezzanines. LSF ceiling Joist members can also be utilized for pitched, mansard and flat roofs. The use of Bailey LSF Joist members will provide support for interior drywall ceilings where long clear spans are required.

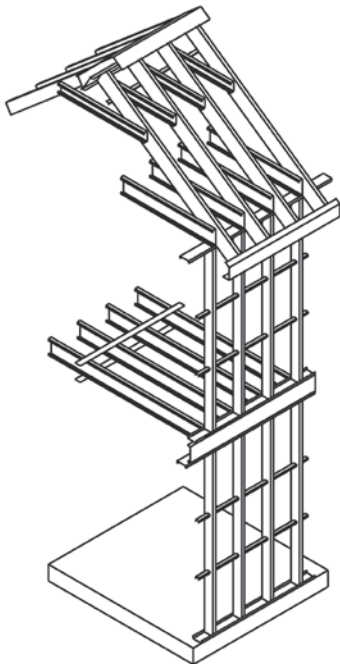

JOISTS FOR FLOORS & ROOFS

Bailey Non-Loadbearing Walls (BNLB)

Lightweight Steel Framing (LSF) provides an effective solution for interior non-load bearing walls and partitions. When combined with top track deflection members, bulkheads will resist buckling caused by deflection of floor and roof assemblies. Non-load bearing LSF provides a stable framework for drywall or other finished wall surface applications.

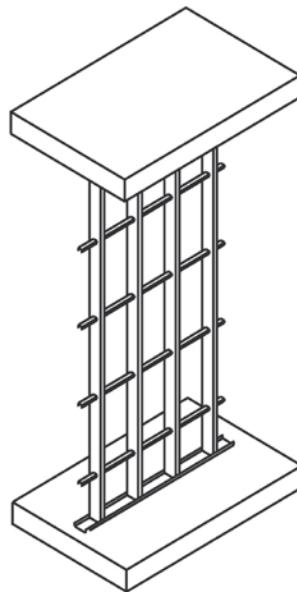

TALL INTERIOR PARTITIONS

Bailey Spandrel Walls

Lightweight Steel Framing (LSF) accommodates a variety of spans for continuous strip window applications. LSF provides a stable, square platform in which glazing units and frames can be effectively installed.

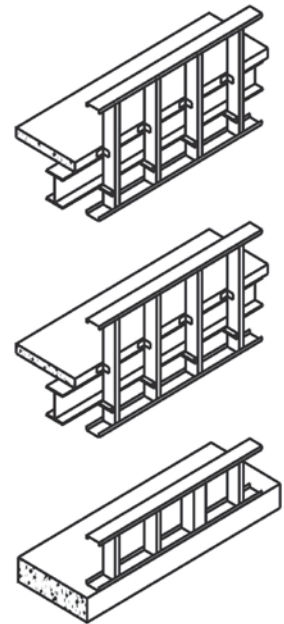

SPANDREL WALLS FOR CONTINUOUS STRIP WINDOWS



WALL ELEVATIONS

WIND LOADBEARING
INFILL WALL

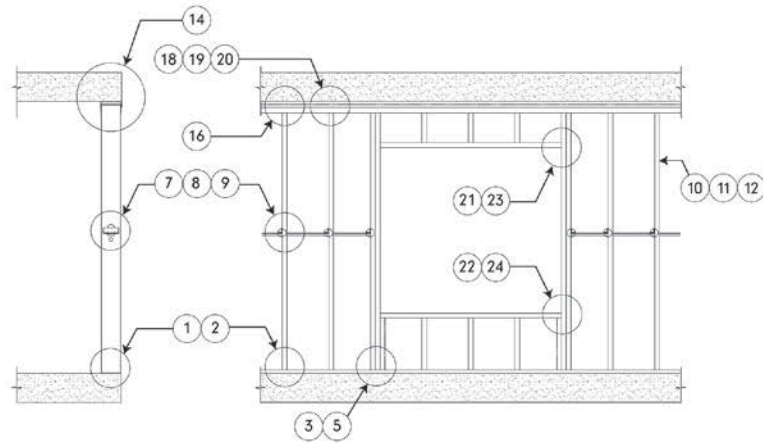

WIND LOADBEARING
CONTINUOUS
CURTAIN WALLS

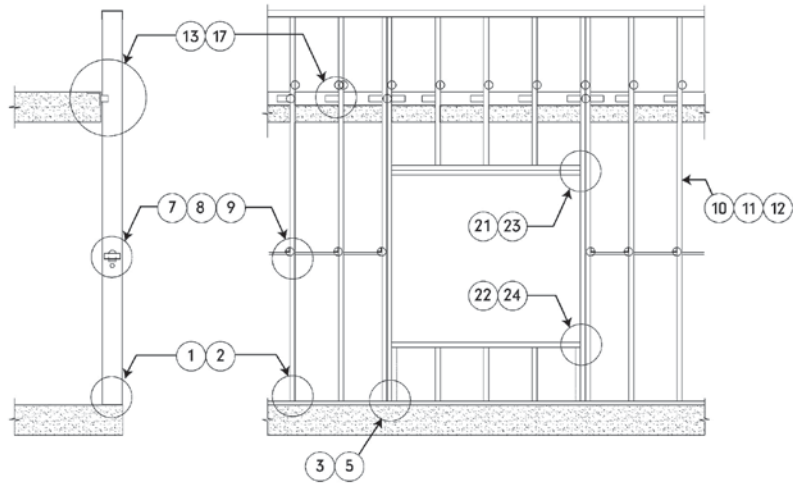

WIND LOADBEARING
SPANDREL WALL FOR
STRIP WINDOWS

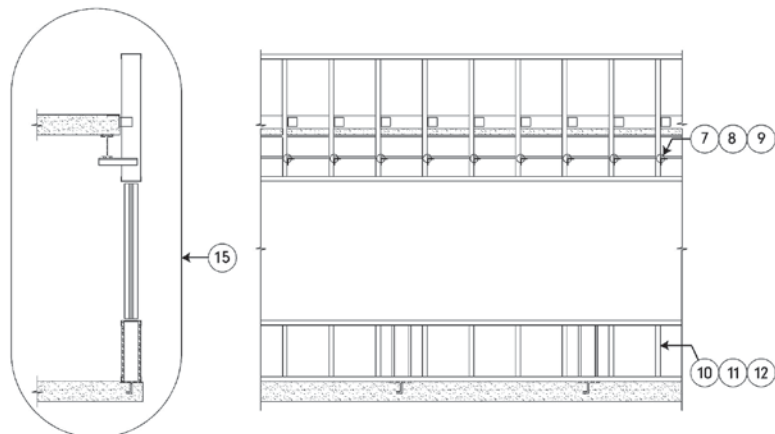

GENERAL DETAILS

1

BAILEY STUD TO BAILEY TRACK

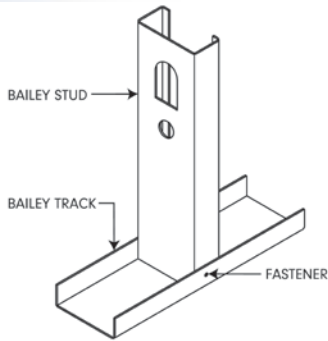

2

BAILEY STUD TO BAILEY PATENTED PUNCHED TRACK

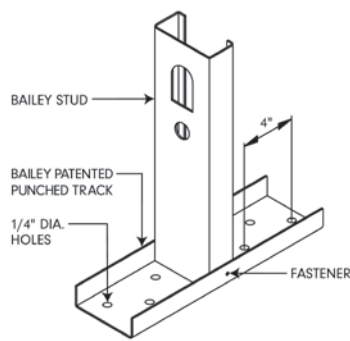

3

BAILEY STUD REINFORCED WITH BAILEY TRACK

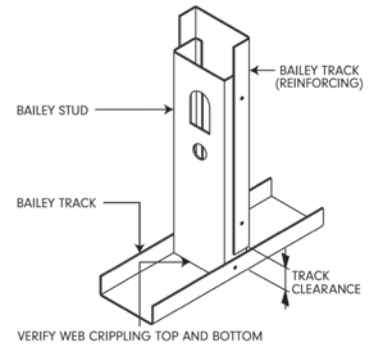

4

BAILEY STUD WITH WEB STIFFENER REINFORCING

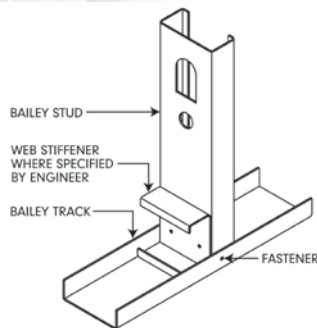

5

JAMB STUD AT DOOR OPENING

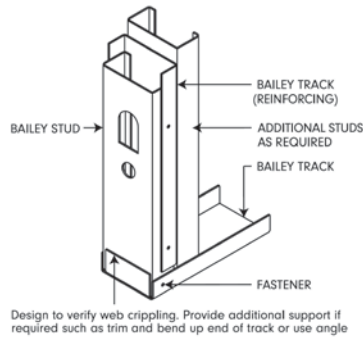

6

BAILEY STUD TO BAILEY TRACK AT CORNERS

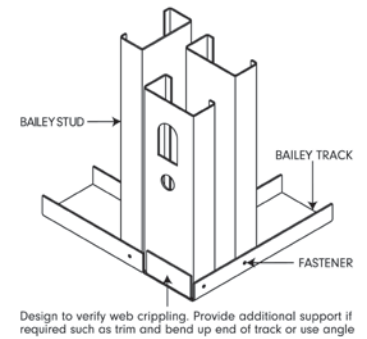

7

THROUGH-THE-STUD BRIDGING

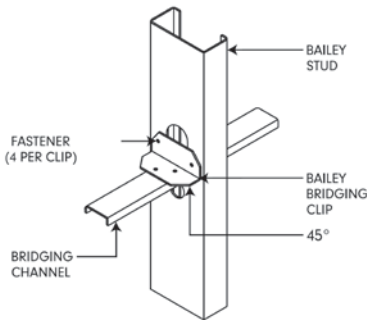

8

FLAT STRAP BRIDGING

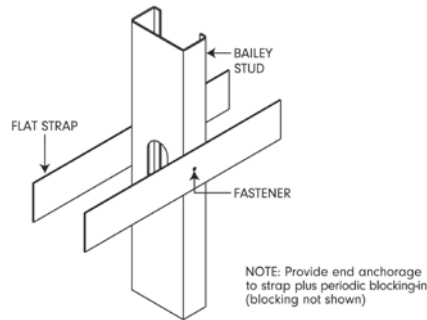

9

NOTCHED CHANNEL BRIDGING

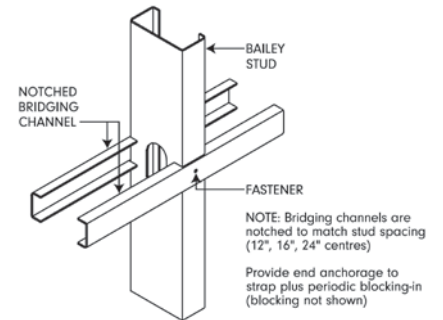

10

EXTERIOR SHEATHING

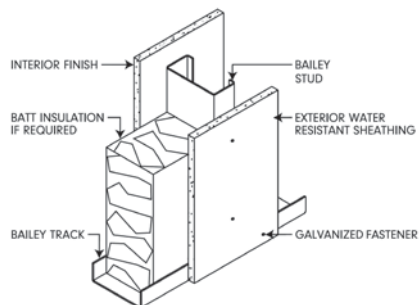

11

EXTERIOR RIGID INSULATION

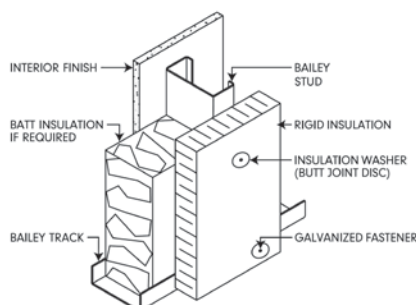

12

EXTERIOR SHEATHING AND RIGID INSULATION

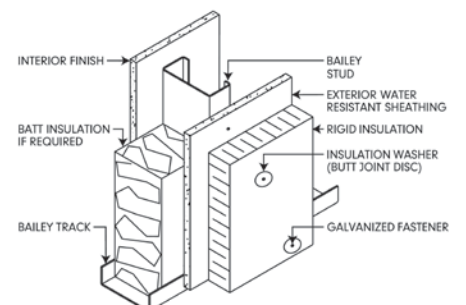



WIND BEARING WALLS

13

CONTINUOUS WIND BEARING STUD AT PARAPET

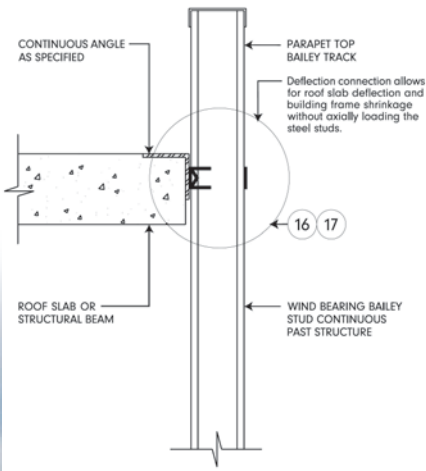

14

WIND BEARING INFILL WALL

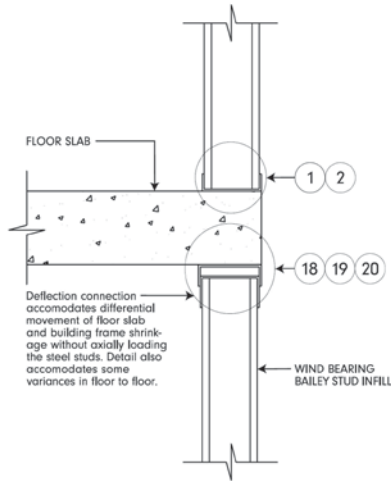

15

SPANDREL WALL FOR STRIP WINDOWS

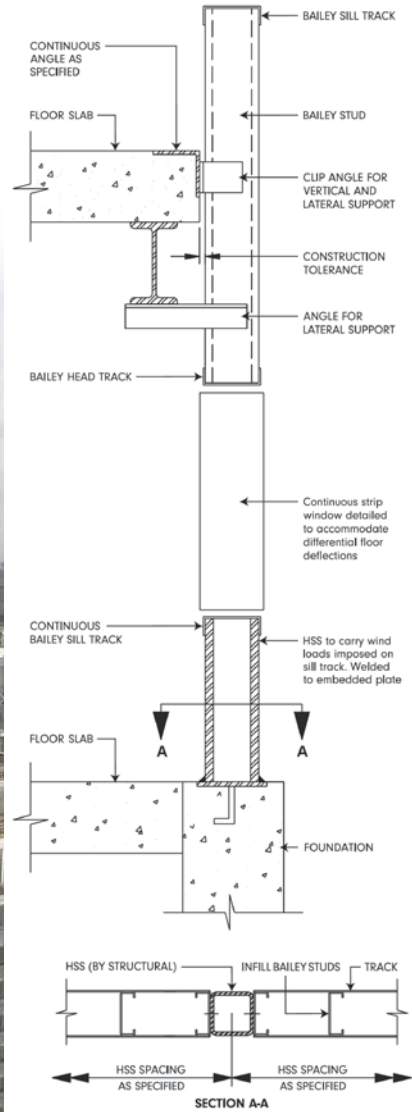



WIND BEARING WALLS – DEFLECTION DETAILS

16 SINGLE DEFLECTION TRACK

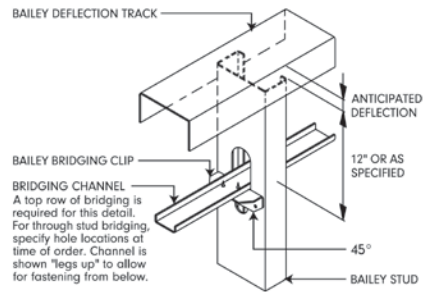

17 HORIZONTAL FLANGE ATTACHMENT (HFA) CLIP

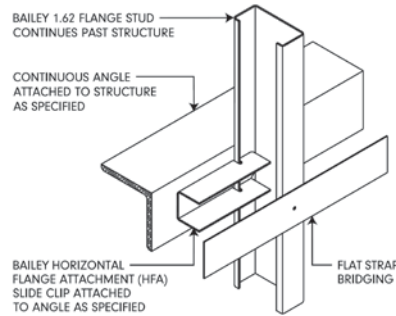

18 DEFLECTION TRACK

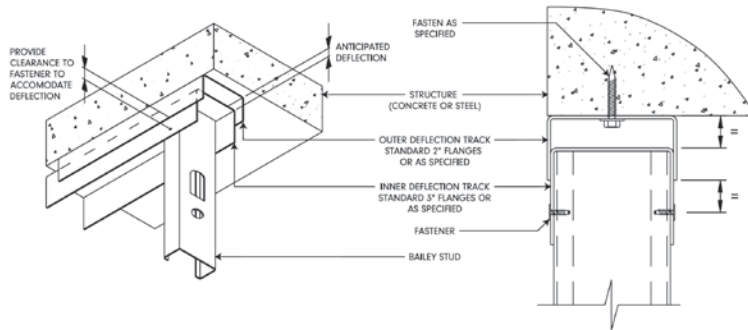

19 SLOTTED DEFLECTION CLIP (Radius Wall Applications)

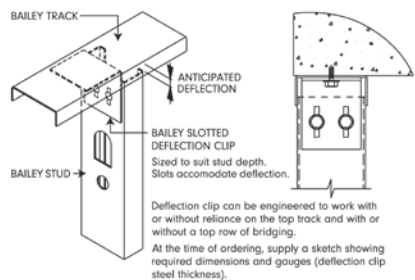

20 BAILEY MULTI-SLOT TRACK

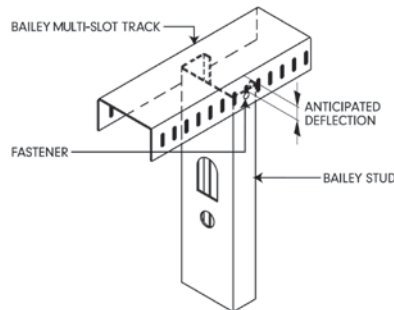

WIND BEARING WALLS – DETAILS AT OPENINGS

21 HEAD TRACK TO JAMB STUDS

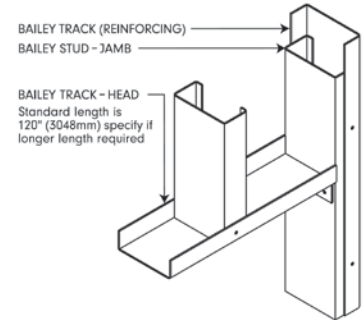

22 SILL TRACK TO JAMB STUDS

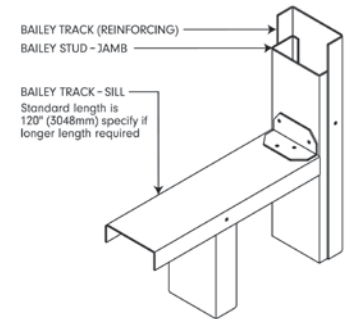

23 REINFORCED HEAD TRACK TO JAMB STUD

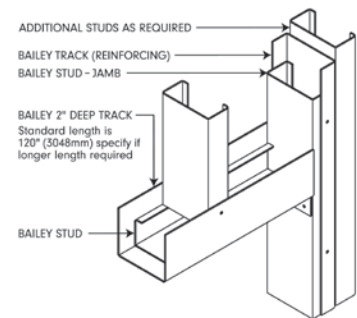

24 REINFORCED SILL TRACK TO JAMB STUD

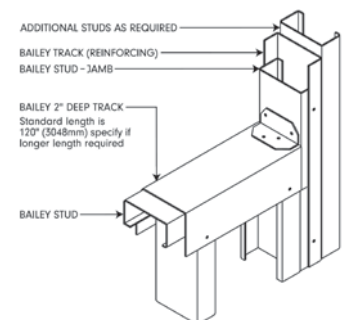



BAILEY[®]

METAL PRODUCTS LIMITED

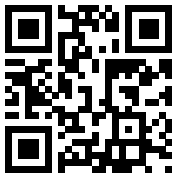

LIGHTWEIGHT STEEL FRAMING DETAILS GENERAL & WIND BEARING

sales@bmp-group.com • www.bmp-group.com



GW807IN16-500

MONTREAL

525 Avenue Edward VII
Dorval, QC H9P 1E7
Tel. (514) 735-3455
800-263-3455
Fax. (514) 735-5052

TORONTO

1 Caldari Road
Concord, ON L4K 3Z9
Tel. (905) 738-9267
800-668-2154
Fax. (905) 738-5712

CALGARY

3924 27th Street NE
Calgary, AB T1Y 5K7
Tel. (403) 248-3536
800-665-2013
Fax. (403) 248-0288

EDMONTON

5710 Roper Road NW
Edmonton, AB T6B 3G7
Tel. (780) 462-5757
800-563-1751
Fax. (780) 450-3378

VANCOUVER

7715 Anvil Way
Surrey, BC V3W 6A2
Tel. (604) 590-5100
800-818-2666
Fax. (604) 590-5105