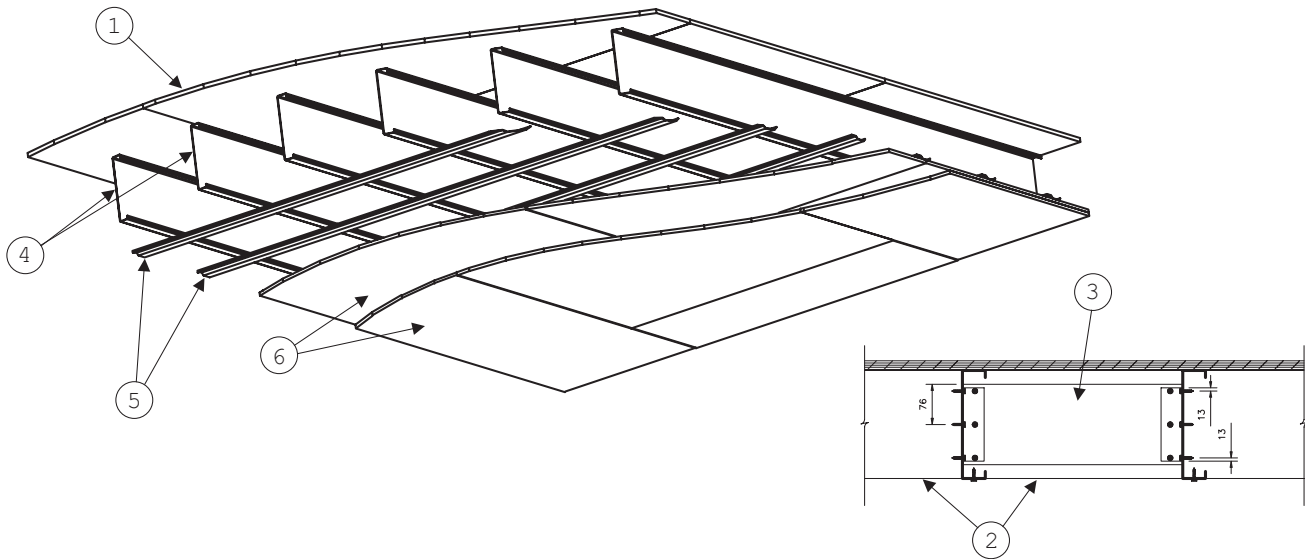

Fire Protection

CANADIAN STEEL CONSTRUCTION COUNCIL

201 Consumers Road, Suite 300
Willowdale, Ontario, M2J 4G8

Floor Assembly No. NRC764-FF22

Fire Endurance Period ¹ – 74 minutesSound Transmission Class (STC) ² – 44Impact Insulation Classification (IIC) ² – 40 & 60 ³

Notes:

- ¹ Fire testing done by the Fire Risk Management Program, Institute for Research in Construction, National Research Council Canada [1] in accordance with the requirements of CAN/ULC-S101 [2].
- ² Sound transmission testing done by the Acoustics Laboratory, Institute for Research in Construction, National Research Council Canada [3] and [4] in accordance with the requirements of ASTM E90 [5] and ASTM E413 [6] for STC, and ASTM E492 [7] and ASTM E989 [8] for ICC.
- ³ With carpet and pad [4].

Combustible Construction

- 1. Sub-Flooring** – 15.9 mm thick, tongue and groove, Canadian softwood plywood (CSP) laid perpendicular to joist with staggered end joints butted over joists. Fastened to every joist with #10 self-drilling bugle head screws 32 mm long spaced at 300 mm O.C. in the field and 150 mm O.C. at the butt ends
- 2. Bridging** – 51 mm wide by 1.52 mm thick steel strap fastened to underside of every joist with 19 mm long #8 self-drilling wafer-head screws.

- 3. Blocking** – 152 mm deep by 41 mm wide by 1.21 mm thick C-shaped section located between rim joist and adjacent joist and in every fifth space between joists thereafter. Blocking is fastened to joist at mid height of joist with 41 mm by 41 mm by 1.21 mm steel clip angles 126 mm long using 3 - 19 mm long #8 self-drilling wafer-head screws in each leg.
- 4. Steel Joist** – 203 mm deep by 41 mm wide by 1.21 mm thick C-shaped steel sections as found in the CSSBI Member Selection Tables [9] conforming to CAN/CGSB-7 “Cold Formed Steel Framing Components” and spaced at 406 mm.
- 5. Resilient Channels** – 12.7 mm deep single-leg resilient channels formed from 0.46 mm thick galvanized steel. Channel is 57 mm overall width with a 32 mm bearing surface. Channel is laid perpendicular to joist, is spaced at 406 mm O.C. and fastened to underside of each joist through the flange lip with 19 mm long #8 self-drilling screws.
- 6. Gypsum Wallboard** – 2 layers of 12.7 mm thick by 1219 mm wide Type X gypsum wallboard conforming to the requirements of CAN/CSA-A82.27-M91 “Gypsum Board-Building Materials and Products”. Base layer of gypsum wallboard installed with long dimension perpendicular to the resilient channels and end joints of adjacent boards, staggered 2030 mm and located under resilient channels. Screwed to each resilient channel with 32 mm long Type “S” screws, located 38 mm from edge of board or 10 mm from the ends of board, 272 mm from each edge screw, and 300 mm O.C. in the field of the board. Face layer installed with long dimension perpendicular to the resilient channels and end joints of adjacent boards located between resilient channels. End joints staggered at least 609 mm from those of the base layer and 812 mm those of adjacent boards. Joints in the long direction staggered 610 mm from those of the base layer. Attached through base layer to each resilient channel with 41 mm long Type “S” screws, located 38 mm from the board edges, 272 mm from each edge screw, and 300 mm O.C. in the field of the board. Ends of the board attached to the base layer with 38 mm long Type “G” screws, located 38 mm from the board ends, 51 mm from each edge and 109 mm from each edge screw, and 300 mm O.C. in the field of the board.
- 7. Wallboard Screws** – Type “S” and Type “G” self-drilling and self-tapping screws, 32 mm, 38 mm and 41 mm long.
- 8. Joint System** (not shown) – Paper tape embedded in joint compound over joints and exposed screw heads with edges of compound feathered out.

References:

- [1] Sultan, M.A., Séguin, Y.P. and Leroux, P., *Results of Fire Resistance Tests on Full-Scale Floor Assemblies*, IRC Internal Report No. 764, National Research Council of Canada, Ottawa, Ontario, Canada, 1998.
- [2] Underwriters' Laboratories of Canada, *Standard Methods of Fire Endurance Tests of Building Construction and Materials*, CAN/ULC-S101-89, Scarborough, Ontario, Canada, 1989.
- [3] Warnock, A.C.C. and Birta, J.A., *Summary Report for Consortium on Fire Resistance and Sound Insulation of Floors: Sound Transmission Class and Impact Insulation Class Results*, IRC Internal Report No. 766, National Research Council of Canada, Ottawa, Ontario, Canada, 1998.
- [4] Warnock, A.C.C., *Sound Transmission Estimates for Steel-Framed Floor Assemblies*, Institute for Research in Construction, National Research Council of Canada, Ottawa, Ontario, Canada, January 12, 2000.
- [5] American Society for Testing and Materials, *Standard Test Method for Laboratory Measurement of Airborne Sound Transmission Loss of Building Partitions*, ASTM E90, Philadelphia, Pennsylvania.
- [6] American Society for Testing and Materials, *Classification for Rating Sound Insulation*, ASTM E413, Philadelphia, Pennsylvania.
- [7] American Society for Testing and Materials, *Standard Test Method for Laboratory Measurement of Impact Sound Transmission through Floor-ceiling Assemblies using the Tapping Machine*, ASTM E492, Philadelphia, Pennsylvania.
- [8] American Society for Testing and Materials, *Standard Classification for Determination of Impact Insulation Class*, ASTM E989, Philadelphia, Pennsylvania.
- [9] Canadian Sheet Steel Building Institute, *CSSBI Residential Steel Framing Member Selection Tables*, S13-99, Cambridge, Ontario.

Fire Protection

CANADIAN STEEL CONSTRUCTION COUNCIL

201 Consumers Road, Suite 300
Willowdale, Ontario, M2J 4G8

Floor Assembly No. NRC764-FF23

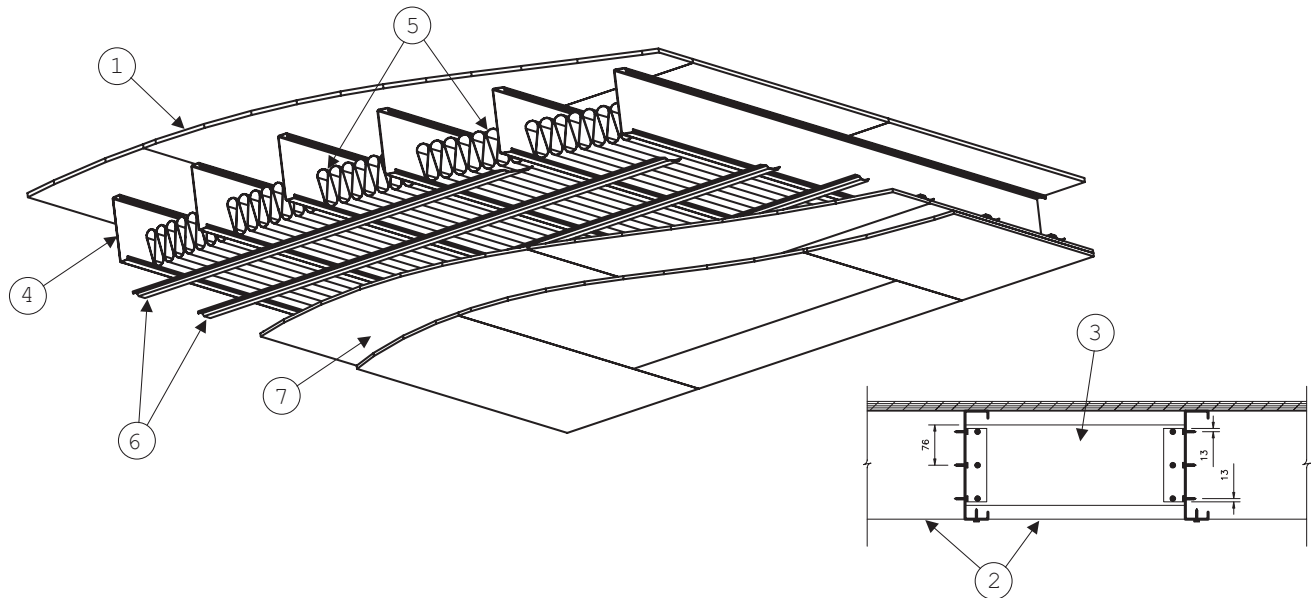
Fire Endurance Period ¹ – 68 minutesSound Transmission Class (STC) ² – 48 ⁴ & 52 ³Impact Insulation Classification (IIC) ² – 39 & 69 ³

Notes:

- ¹ Fire testing done by the Fire Risk Management Program, Institute for Research in Construction, National Research Council Canada [1] in accordance with the requirements of CAN/ULC-S101 [2].
- ² Sound transmission testing done by the Acoustics Laboratory, Institute for Research in Construction, National Research Council Canada [3] and [4] in accordance with the requirements of ASTM E90 [5] and ASTM E413 [6] for STC, and ASTM E492 [7] and ASTM E989 [8] for ICC.
- ³ With carpet and pad [4].
- ⁴ Sound transmission testing done by the Acoustics Laboratory to compare the relative performance of Oriented Strand Board (OSB) and plywood sub-flooring [3] indicates that a 52 STC would result if OSB is used in this assembly.

Combustible Construction

1. Sub-Flooring – 15.9 mm thick, tongue and groove, Canadian softwood plywood (CSP) laid perpendicular to joist with staggered end joints butted over joists. Fastened to every joist with #10 self-drilling bugle head screws 32 mm long spaced at 300 mm O.C. in the field and 150 mm O.C. at the butt ends.

2. **Bridging** – 51 mm wide by 1.52 mm thick steel strap fastened to underside of every joist with 19 mm long #8 self-drilling wafer-head screws.
3. **Blocking** – 152 mm deep by 41 mm wide by 1.21 mm thick C-shaped section located between rim joist and first steel joist and every fifth space between joists thereafter. Blocking is fastened to joist at mid height of joist with 41 mm by 41 mm by 1.21 mm steel clip angles 126 mm long using 3 - 19 mm long #8 self-drilling wafer-head screws in each leg.
4. **Steel Joist** – 203 mm deep by 41 mm wide by 1.21 mm thick C-shaped steel sections as found in the CSSBI Member Selection Tables [9] conforming to CAN/CGSB-7 “Cold Formed Steel Framing Components” and spaced at 406 mm.
5. **Batt Insulation** – 90 mm thick glass fibre sound attenuation blanket conforming to CSA-A101 “Thermal Insulation” resting on resilient channels and cut to fit tightly between webs of joist.
6. **Resilient Channels** – 12.7 mm deep single-leg resilient channels formed from 0.46 mm thick galvanized steel. Channel is 57 mm overall width with a 32 mm bearing surface. Channel is laid perpendicular to joist, is spaced at 406 mm O.C. and fastened to underside of each joist through the flange lip with 19 mm long #8 self-drilling screws.
7. **Gypsum Wallboard** – 2 layers of 12.7 mm thick by 1219 mm wide Type X gypsum wallboard conforming to the requirements of CAN/CSA-A82.27-M91 “Gypsum Board-Building Materials and Products”. Base layer of gypsum wallboard installed with long dimension perpendicular to the resilient channels and end joints of adjacent boards, staggered 2030 mm and located under resilient channels. Screwed to each resilient channel with 32 mm long Type “S” screws, located 38 mm from edge of board or 10 mm from the ends of board, 272 mm from each edge screw, and 300 mm O.C. in the field of the board. Face layer installed with long dimension perpendicular to the resilient channels and end joints of adjacent boards located between resilient channels. End joints staggered at least 609 mm from those of the base layer and 812 mm those of adjacent boards. Joints in the long direction staggered 610 mm from those of the base layer. Attached through base layer to each resilient channel with 41 mm long Type “S” screws, located 38 mm from the board edges, 272 mm from each edge screw, and 300 mm O.C. in the field of the board. Ends of the board attached to the base layer with 38 mm long Type “G” screws, located 38 mm from the board ends, 51 mm from each edge and 109 mm from each edge screw, and 300 mm O.C. in the field of the board.
8. **Wallboard Screws** – Type “S” and Type “G” self-drilling and self-tapping screws, 32 mm, 38 mm and 41 mm long.
9. **Joint System** (not shown) – Paper tape embedded in joint compound over joints and exposed screw heads with edges of compound feathered out.

References:

- [1] Sultan, M.A., Séguin, Y.P. and Leroux, P., *Results of Fire Resistance Tests on Full-Scale Floor Assemblies*, IRC Internal Report No. 764, National Research Council of Canada, Ottawa, Ontario, Canada, 1998.
- [2] Underwriters’ Laboratories of Canada, *Standard Methods of Fire Endurance Tests of Building Construction and Materials*, CAN/ULC-S101-89, Scarborough, Ontario, Canada, 1989.
- [3] Warnock, A.C.C. and Birta, J.A., *Summary Report for Consortium on Fire Resistance and Sound Insulation of Floors: Sound Transmission Class and Impact Insulation Class Results*, IRC Internal Report No. 766, National Research Council of Canada, Ottawa, Ontario, Canada, 1998.
- [4] Birta, J.A., *Airborne and Impact Sound Transmission Measurements Performed on Specimen B3163-1 & 2*, IRC Client Reports No. B3163.1 & 2, National Research Council of Canada, Ottawa, Ontario, Canada, March, 2001.
- [5] American Society for Testing and Materials, *Standard Test Method for Laboratory Measurement of Airborne Sound Transmission Loss of Building Partitions*, ASTM E90, Philadelphia, Pennsylvania.
- [6] American Society for Testing and Materials, *Classification for Rating Sound Insulation*, ASTM E413, Philadelphia, Pennsylvania.
- [7] American Society for Testing and Materials, *Standard Test Method for Laboratory Measurement of Impact Sound Transmission through Floor-ceiling Assemblies using the Tapping Machine*, ASTM E492, Philadelphia, Pennsylvania.
- [8] American Society for Testing and Materials, *Standard Classification for Determination of Impact Insulation Class*, ASTM E989, Philadelphia, Pennsylvania.
- [9] Canadian Sheet Steel Building Institute, *CSSBI Residential Steel Framing Member Selection Tables*, S13-99, Cambridge, Ontario.

Fire Protection

CANADIAN STEEL CONSTRUCTION COUNCIL

201 Consumers Road, Suite 300
Willowdale, Ontario, M2J 4G8

Floor Assembly No. NRC764-FF24

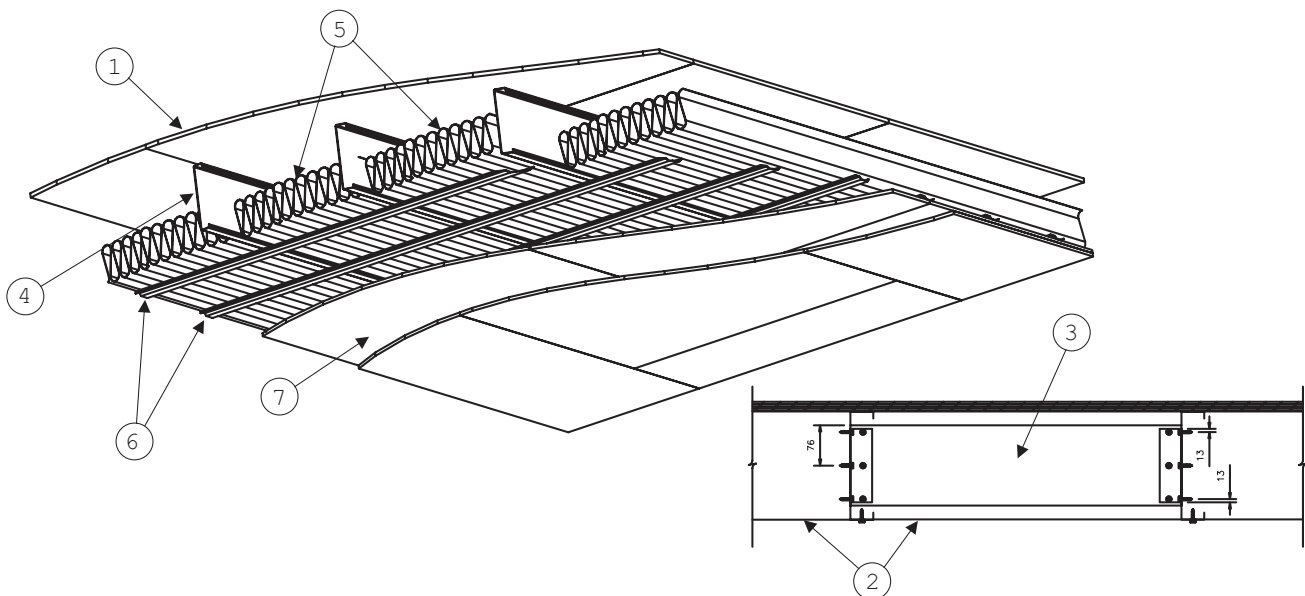
Fire Endurance Period ¹ – 69 minutesSound Transmission Class (STC) ² – 52Impact Insulation Classification (IIC) ² – 42 & 62 ³

Notes:

- ¹ Fire testing done by the Fire Risk Management Program, Institute for Research in Construction, National Research Council Canada [1] in accordance with the requirements of CAN/ULC-S101 [2].
- ² Sound transmission testing done by the Acoustics Laboratory, Institute for Research in Construction, National Research Council Canada [3] and [4] in accordance with the requirements of ASTM E90 [5] and ASTM E413 [6] for STC, and ASTM E492 [7] and ASTM E989 [8] for ICC.
- ³ With carpet and pad [4].

Combustible Construction

- 1. Sub-Flooring** – 19.0 mm thick, tongue and groove, Canadian softwood plywood (CSP) laid perpendicular to joist with staggered end joints butted over joists. Fastened to every joist with #10 self-drilling bugle head screws 32 mm long spaced at 300 mm O.C. in the field and 150 mm O.C. at the butt ends.
- 2. Bridging** – 51 mm wide by 1.52 mm thick steel strap fastened to underside of every joist with 19 mm long #8 self-drilling wafer-head screws.



Algoma Steel Inc. • Dofasco Inc. • Ispat Sidbec Inc. • Stelco Inc.
Canadian Fasteners Institute • Canadian Institute of Steel Construction • Canadian Sheet Steel Building Institute
Metals Service Centre Institute • Corrugated Steel Pipe Institute • Canadian Welding Bureau (Associate Member)

- 3. Blocking** – 152 mm deep by 41 mm wide by 1.21 mm thick C-shaped section located between rim joist and adjacent joist and in every fifth space between joists thereafter. Blocking is fastened to joist at mid height of joist with 41 mm by 41 mm by 1.21 mm steel clip angles 126 mm long using 3 - 19 mm long #8 self-drilling wafer-head screws in each leg.
- 4. Steel Joist** – 203 mm deep by 41 mm wide by 1.21 mm thick C-shaped steel sections as found in the CSSBI Member Selection Tables [9] conforming to CAN/CGSB-7 “Cold Formed Steel Framing Components” and spaced at 610 mm.
- 5. Batt Insulation** – 90 mm thick glass fibre sound attenuation blanket conforming to CSA-A101 “Thermal Insulation” resting on resilient channels and cut to fit tightly between webs of joist.
- 6. Resilient Channels** – 12.7 mm deep single-leg resilient channels formed from 0.46 mm thick galvanized steel. Channel is 57 mm overall width with a 32 mm bearing surface. Channel is laid perpendicular to joist, is spaced at 406 mm O.C. and fastened to underside of each joist through the flange lip with 19 mm long #8 self-drilling screws.
- 7. Gypsum Wallboard** – 2 layers of 12.7 mm thick by 1219 mm wide Type X gypsum wallboard conforming to the requirements of CAN/CSA-A82.27-M91 “Gypsum Board-Building Materials and Products”. Base layer of gypsum wallboard installed with long dimension perpendicular to the resilient channels and end joints of adjacent boards, staggered 2030 mm and located under resilient channels. Screwed to each resilient channel with 32 mm long Type “S” screws, located 38 mm from edge of board or 10 mm from the ends of board, 272 mm from each edge screw, and 300 mm O.C. in the field of the board. Face layer installed with long dimension perpendicular to the resilient channels and end joints of adjacent boards located between resilient channels. End joints staggered at least 609 mm from those of the base layer and 812 mm those of adjacent boards. Joints in the long direction staggered 610 mm from those of the base layer. Attached through base layer to each resilient channel with 41 mm long Type “S” screws, located 38 mm from the board edges, 272 mm from each edge screw, and 300 mm O.C. in the field of the board. Ends of the board attached to the base layer with 38 mm long Type “G” screws, located 38 mm from the board ends, 51 mm from each edge and 109 mm from each edge screw, and 300 mm O.C. in the field of the board.
- 8. Wallboard Screws** – Type “S” and Type “G” self-drilling and self-tapping screws, 32 mm, 38 mm and 41 mm long.
- 9. Joint System** (not shown) – Paper tape embedded in joint compound over joints and exposed screw heads with edges of compound feathered out.

References:

- [1] Sultan, M.A., Séguin, Y.P. and Leroux, P., *Results of Fire Resistance Tests on Full-Scale Floor Assemblies*, IRC Internal Report No. 764, National Research Council of Canada, Ottawa, Ontario, Canada, 1998.
- [2] Underwriters’ Laboratories of Canada, *Standard Methods of Fire Endurance Tests of Building Construction and Materials*, CAN/ULC-S101-89, Scarborough, Ontario, Canada, 1989.
- [3] Warnock, A.C.C. and Birta, J.A., *Summary Report for Consortium on Fire Resistance and Sound Insulation of Floors: Sound Transmission Class and Impact Insulation Class Results*, IRC Internal Report No. 766, National Research Council of Canada, Ottawa, Ontario, Canada, 1998.
- [4] Warnock, A.C.C., *Sound Transmission Estimates for Steel-Framed Floor Assemblies*, Institute for Research in Construction, National Research Council of Canada, Ottawa, Ontario, Canada, January 12, 2000.
- [5] American Society for Testing and Materials, *Standard Test Method for Laboratory Measurement of Airborne Sound Transmission Loss of Building Partitions*, ASTM E90, Philadelphia, Pennsylvania.
- [6] American Society for Testing and Materials, *Classification for Rating Sound Insulation*, ASTM E413, Philadelphia, Pennsylvania.
- [7] American Society for Testing and Materials, *Standard Test Method for Laboratory Measurement of Impact Sound Transmission through Floor-ceiling Assemblies using the Tapping Machine*, ASTM E492, Philadelphia, Pennsylvania.
- [8] American Society for Testing and Materials, *Standard Classification for Determination of Impact Insulation Class*, ASTM E989, Philadelphia, Pennsylvania.
- [9] Canadian Sheet Steel Building Institute, *CSSBI Residential Steel Framing Member Selection Tables*, S13-99, Cambridge, Ontario.

Fire Protection

CANADIAN STEEL CONSTRUCTION COUNCIL

201 Consumers Road, Suite 300
Willowdale, Ontario, M2J 4G8

Floor Assembly No. NRC764-FF25

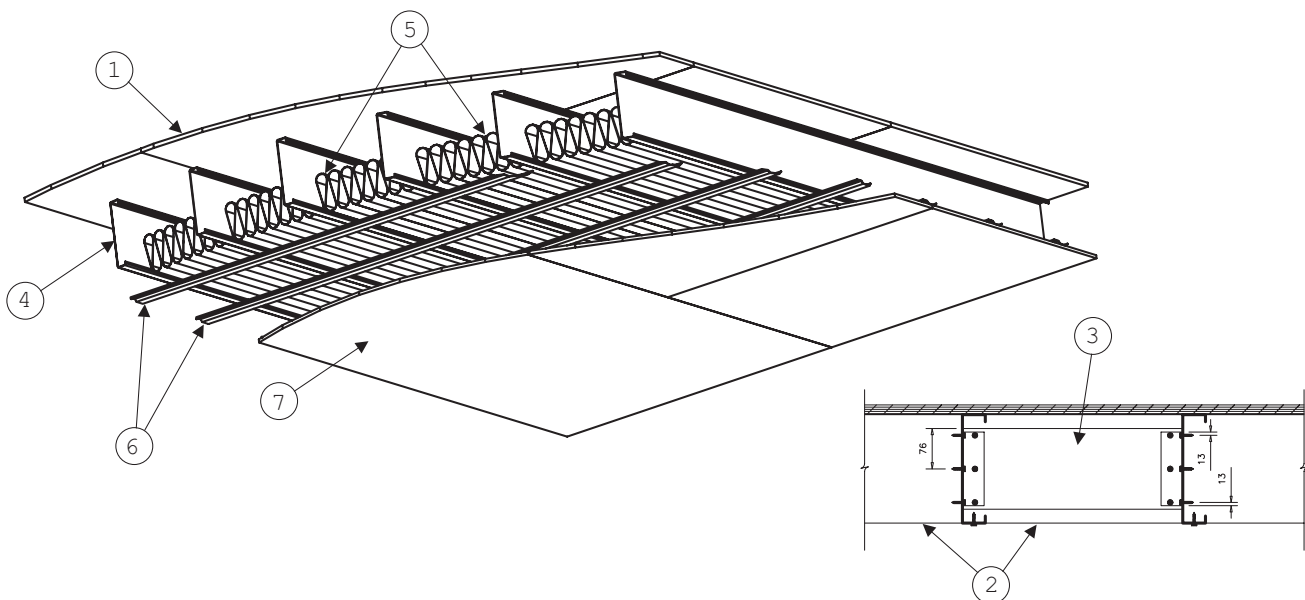
Fire Endurance Period ¹ – 46 minutesSound Transmission Class (STC) ² – 51Impact Insulation Classification (IIC) ² – 44 & 64 ³

Notes:

- ¹ Fire testing done by the Fire Risk Management Program, Institute for Research in Construction, National Research Council Canada [1] in accordance with the requirements of CAN/ULC-S101 [2].
- ² Sound transmission testing done by the Acoustics Laboratory, Institute for Research in Construction, National Research Council Canada [3] and [4] in accordance with the requirements of ASTM E90 [5] and ASTM E413 [6] for STC, and ASTM E492 [7] and ASTM E989 [8] for ICC.
- ³ With carpet and pad [4].

Combustible Construction

- 1. Sub-Flooring** – 15.9 mm thick, tongue and groove, Canadian softwood plywood (CSP) laid perpendicular to joist with staggered end joints butted over joists. Fastened to every joist with #10 self-drilling bugle head screws 32 mm long spaced at 300 mm O.C. in the field and 150 mm O.C. at the butt ends.
- 2. Bridging** – 51 mm wide by 1.52 mm thick steel strap fastened to underside of every joist with 19 mm long #8 self-drilling wafer-head screws.



Algoma Steel Inc. • Dofasco Inc. • Ispat Sidbec Inc. • Stelco Inc.
Canadian Fasteners Institute • Canadian Institute of Steel Construction • Canadian Sheet Steel Building Institute
Metals Service Centre Institute • Corrugated Steel Pipe Institute • Canadian Welding Bureau (Associate Member)

3. **Blocking** – 152 mm deep by 41 mm wide by 1.21 mm thick C-shaped section located between rim joist and adjacent joist and in every fifth space between joists thereafter. Blocking is fastened to joist at mid height of joist with 41 mm by 41 mm by 1.21 mm steel clip angles 126 mm long using 3 - 19 mm long #8 self-drilling wafer-head screws in each leg.
4. **Steel Joist** – 203 mm deep by 41 mm wide by 1.21 mm thick C-shaped steel sections as found in the CSSBI Member Selection Tables [9] conforming to CAN/CGSB-7 “Cold Formed Steel Framing Components” and spaced at 406 mm.
5. **Batt Insulation** – 90 mm thick mineral fibre sound attenuation blanket conforming to CAN/ULC S702-M97 “Standard for Mineral Fibre Thermal Insulation for Buildings” resting on resilient channels and cut to fit tightly between webs of joist.
6. **Resilient Channels** – 12.7 mm deep single-leg resilient channels formed from 0.46 mm thick galvanized steel. Channel is 57 mm overall width with a 32 mm bearing surface. Channel is laid perpendicular to joist, is spaced at 406 mm O.C. and fastened to underside of each joist through the flange lip with 19 mm long #8 self-drilling screws.
7. **Gypsum Wallboard** – 12.7 mm thick by 1219 mm wide Type X gypsum wallboard conforming to the requirements of CAN/CSA-A82.27-M91 “Gypsum Board-Building Materials and Products”. Installed with long dimension perpendicular to the resilient channels and end joints of adjacent boards, staggered 2030 mm and located under resilient channels. Screwed to each resilient channel with 32 mm long Type “S” screws, located 38 mm from edge of board or 10 mm from the ends of board, 272 mm from each edge screw, and 300 mm O.C. in the field of the board.
8. **Wallboard Screws** – Type “S” and Type “G” self-drilling and self-tapping screws, 32 mm, 38 mm and 41 mm long.
9. **Joint System** (not shown) – Paper tape embedded in joint compound over joints and exposed screw heads with edges of compound feathered out.

References:

- [1] Sultan, M.A., Séguin, Y.P. and Leroux, P., *Results of Fire Resistance Tests on Full-Scale Floor Assemblies*, IRC Internal Report No. 764, National Research Council of Canada, Ottawa, Ontario, Canada, 1998.
- [2] Underwriters' Laboratories of Canada, *Standard Methods of Fire Endurance Tests of Building Construction and Materials*, CAN/ULC-S101-89, Scarborough, Ontario, Canada, 1989.
- [3] Warnock, A.C.C. and Birta, J.A., *Summary Report for Consortium on Fire Resistance and Sound Insulation of Floors: Sound Transmission Class and Impact Insulation Class Results*, IRC Internal Report No. 766, National Research Council of Canada, Ottawa, Ontario, Canada, 1998.
- [4] Warnock, A.C.C., *Sound Transmission Estimates for Steel-Framed Floor Assemblies*, Institute for Research in Construction, National Research Council of Canada, Ottawa, Ontario, Canada, January 12, 2000.
- [5] American Society for Testing and Materials, *Standard Test Method for Laboratory Measurement of Airborne Sound Transmission Loss of Building Partitions*, ASTM E90, Philadelphia, Pennsylvania.
- [6] American Society for Testing and Materials, *Classification for Rating Sound Insulation*, ASTM E413, Philadelphia, Pennsylvania.
- [7] American Society for Testing and Materials, *Standard Test Method for Laboratory Measurement of Impact Sound Transmission through Floor-ceiling Assemblies using the Tapping Machine*, ASTM E492, Philadelphia, Pennsylvania.
- [8] American Society for Testing and Materials, *Standard Classification for Determination of Impact Insulation Class*, ASTM E989, Philadelphia, Pennsylvania.
- [9] Canadian Sheet Steel Building Institute, *CSSBI Residential Steel Framing Member Selection Tables*, S13-99, Cambridge, Ontario.

Fire Protection

CANADIAN STEEL CONSTRUCTION COUNCIL

201 Consumers Road, Suite 300
Willowdale, Ontario, M2J 4G8

Floor Assembly No. NRC764-FF26

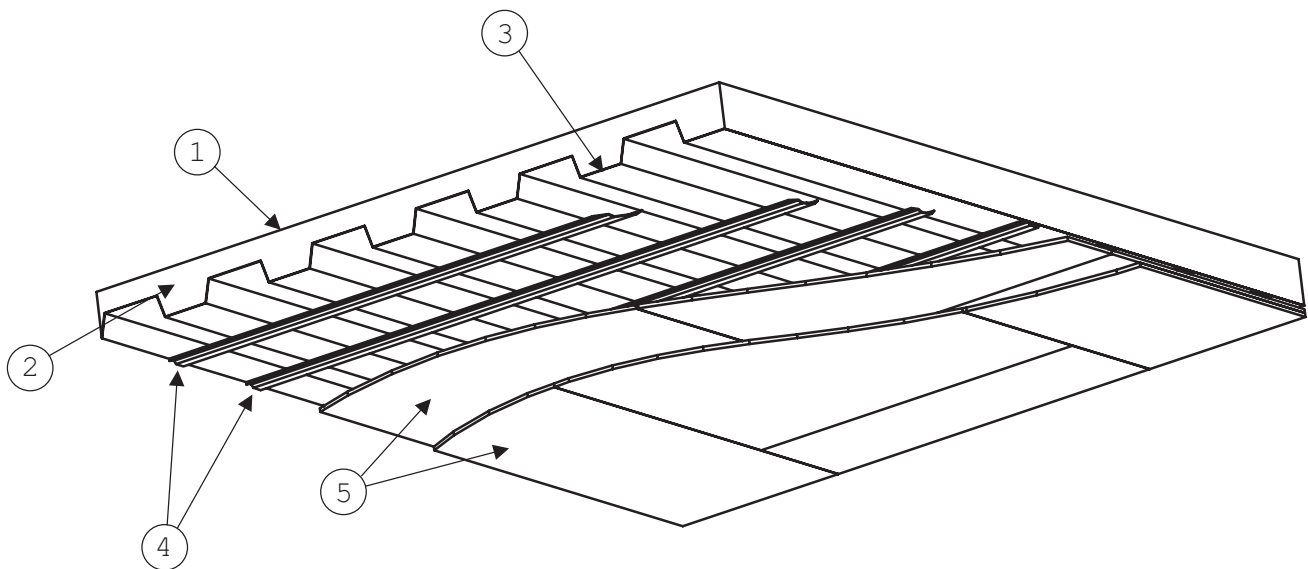
Fire Endurance Period ¹ – 105 minutesSound Transmission Class (STC) ² – 57Impact Insulation Classification (IIC) ² – 36 & 70 ³

Notes:

- ¹ Fire testing done by the Fire Risk Management Program, Institute for Research in Construction, National Research Council Canada [1] in accordance with the requirements of CAN/ULC-S101 [2].
- ² Sound transmission testing done by the Acoustics Laboratory, Institute for Research in Construction, National Research Council Canada [3] and [4] in accordance with the requirements of ASTM E90 [5] and ASTM E413 [6] for STC, and ASTM E492 [7] and ASTM E989 [8] for ICC.
- ³ With carpet and pad [4].

Noncombustible Construction

- 1. Sand-Gravel Concrete** – Normal-density concrete of 2400 kg/m³, 19 mm coarse aggregate, 75 mm slump and 28 day compressive strength of 25 MPa. Minimum 76 mm concrete cover thickness.
- 2. Wire Fabric** – 152 by 152 MW3.8/MW3.8 welded steel wire mesh located 38 mm from top of concrete.
- 3. Steel Floor Units** – Composite, 76 mm deep, galvanized, fluted floor units, 0.91 mm thick.

4. Resilient Channels – inverted hat-shaped section formed from 0.46 mm thick galvanized steel. Channel is 34 mm overall depth with a single 18 mm flattened flange lip. Channel is laid perpendicular to flutes, is spaced at 406 mm O.C. and fastened to underside of each flute with 19 mm long #8 self-drilling screws.

5. Gypsum Wallboard – 2 layers of 12.7 mm thick by 1219 mm wide Type X gypsum wallboard conforming to the requirements of CAN/CSA-A82.27-M91 "Gypsum Board-Building Materials and Products". Base layer of gypsum wallboard installed with long dimension perpendicular to the resilient channels and end joints of adjacent boards, staggered 2030 mm and located under resilient channels. Screwed to each resilient channel with 32 mm long Type "S" screws, located 38 mm from edge of board or 10 mm from the ends of board, 272 mm from each edge screw, and 300 mm O.C. in the field of the board. Face layer installed with long dimension perpendicular to the resilient channels and end joints of adjacent boards located between resilient channels. End joints staggered at least 609 mm from those of the base layer and 812 mm those of adjacent boards. Joints in the long direction staggered 610 mm from those of the base layer. Attached through base layer to each resilient channel with 41 mm long Type "S" screws, located 38 mm from the board edges, 272 mm from each edge screw, and 300 mm O.C. in the field of the board. Ends of the board attached to the base layer with 38 mm long Type "G" screws, located 38 mm from the board ends, 51 mm from each edge and 109 mm from each edge screw, and 300 mm O.C. in the field of the board.

6. Wallboard Screws – Type "S" and Type "G" self-drilling and self-tapping screws, 32 mm, 38 mm and 41 mm long.

7. Joint System (not shown) – Paper tape embedded in joint compound over joints and exposed screw heads with edges of compound feathered out.

References:

- [1] Sultan, M.A., Séguin, Y.P. and Leroux, P., *Results of Fire Resistance Tests on Full-Scale Floor Assemblies*, IRC Internal Report No. 764, National Research Council of Canada, Ottawa, Ontario, Canada, 1998.
- [2] Underwriters' Laboratories of Canada, *Standard Methods of Fire Endurance Tests of Building Construction and Materials*, CAN/ULC-S101-89, Scarborough, Ontario, Canada, 1989.
- [3] Warnock, A.C.C. and Birta, J.A., *Summary Report for Consortium on Fire Resistance and Sound Insulation of Floors: Sound Transmission Class and Impact Insulation Class Results*, IRC Internal Report No. 766, National Research Council of Canada, Ottawa, Ontario, Canada, 1998.
- [4] Warnock, A.C.C., *Sound Transmission Estimates for Steel-Framed Floor Assemblies*, Institute for Research in Construction, National Research Council of Canada, Ottawa, Ontario, Canada, January 12, 2000.
- [5] American Society for Testing and Materials, *Standard Test Method for Laboratory Measurement of Airborne Sound Transmission Loss of Building Partitions*, ASTM E90, Philadelphia, Pennsylvania.
- [6] American Society for Testing and Materials, *Classification for Rating Sound Insulation*, ASTM E413, Philadelphia, Pennsylvania.
- [7] American Society for Testing and Materials, *Standard Test Method for Laboratory Measurement of Impact Sound Transmission through Floor-ceiling Assemblies using the Tapping Machine*, ASTM E492, Philadelphia, Pennsylvania.
- [8] American Society for Testing and Materials, *Standard Classification for Determination of Impact Insulation Class*, ASTM E989, Philadelphia, Pennsylvania.

Fire Protection

CANADIAN STEEL CONSTRUCTION COUNCIL

201 Consumers Road, Suite 300
Willowdale, Ontario, M2J 4G8

Floor Assembly No. NRC764-FF27

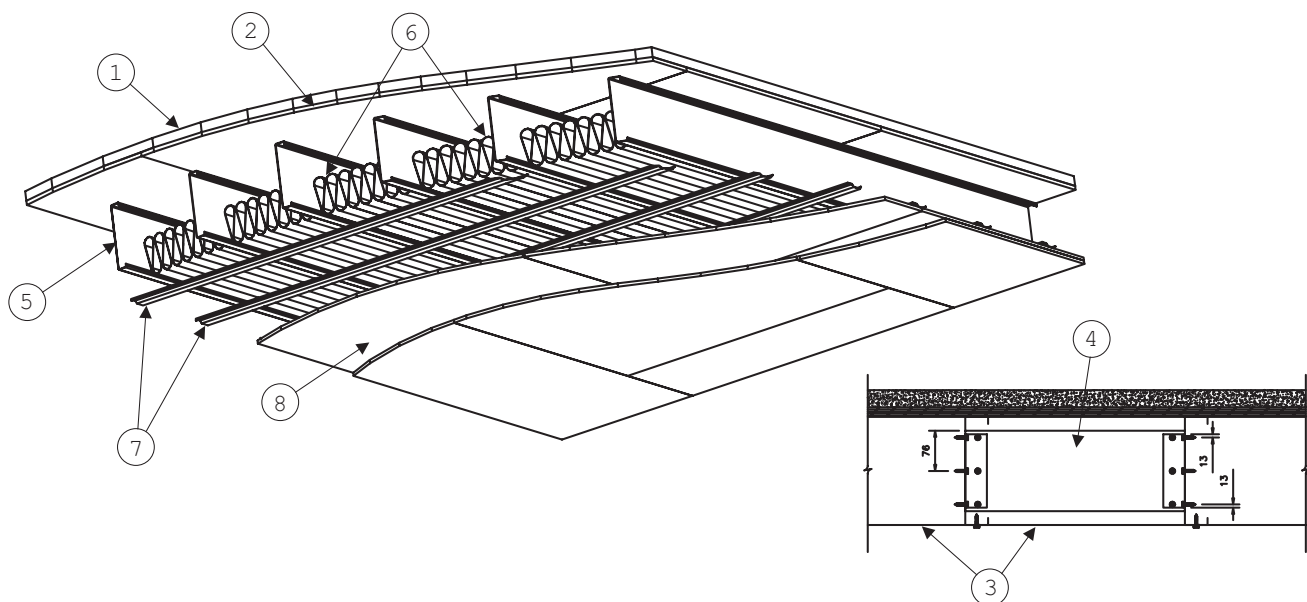
Fire Endurance Period ¹ – 60 minutesSound Transmission Class (STC) ² – 60Impact Insulation Classification (IIC) ² – 31 & 70 ³

Notes:

- ¹ Fire testing done by the Fire Risk Management Program, Institute for Research in Construction, National Research Council Canada [1] in accordance with the requirements of CAN/ULC-S101 [2].
- ² Sound transmission testing done by the Acoustics Laboratory, Institute for Research in Construction, National Research Council Canada [3] and [4] in accordance with the requirements of ASTM E90 [5] and ASTM E413 [6] for STC, and ASTM E492 [7] and ASTM E989 [8] for ICC.
- ³ With carpet and pad [4].

Combustible Construction

- 1. Concrete Topping** – 38 mm thick non-structural topping, density of 2406 kg/m³, 19 mm coarse aggregate, 75 mm slump and 28 day compressive strength of 25 MPa.
- 2. Sub-Flooring** – 15.9 mm thick, tongue and groove, Canadian softwood plywood (CSP) laid perpendicular to joist with staggered end joints butted over joists. Fastened to every joist with #10 self-drilling bugle head screws 32 mm long spaced at 300 mm O.C. in the field and 150 mm O.C. at the butt ends.



Algoma Steel Inc. • Dofasco Inc. • Ispat Sidbec Inc. • Stelco Inc.
Canadian Fasteners Institute • Canadian Institute of Steel Construction • Canadian Sheet Steel Building Institute
Metals Service Centre Institute • Corrugated Steel Pipe Institute • Canadian Welding Bureau (Associate Member)

3. **Bridging** – 51 mm wide by 1.52 mm thick steel strap fastened to underside of every joist with 19 mm long #8 self-drilling wafer-head screws.
4. **Blocking** – 152 mm deep by 41 mm wide by 1.21 mm thick C-shaped section located between rim joist and adjacent joist and in every fifth space between joists thereafter. Blocking is fastened to joist at mid height of joist with 41 mm by 41 mm by 1.21 mm steel clip angles 126 mm long using 3 - 19 mm long #8 self-drilling wafer-head screws in each leg.
5. **Steel Joist** – 203 mm deep by 41 mm wide by 1.21 mm thick C-shaped steel sections as found in the CSSBI Member Selection Tables [9] conforming to CAN/CGSB-7 “Cold Formed Steel Framing Components” and spaced at 406 mm.
6. **Batt Insulation** – 90 mm thick glass fibre sound attenuation blanket conforming to CSA-A101 “Thermal Insulation” resting on resilient channels and cut to fit tightly between webs of joist.
7. **Resilient Channels** – inverted hat-shaped section formed from 0.46 mm thick galvanized steel. Channel is 34 mm overall depth with a single 18 mm flattened flange lip. Channel is laid perpendicular to joist, is spaced at 406 mm O.C. and fastened to underside of each joist through the flange lip with 19 mm long #8 self-drilling screws.
8. **Gypsum Wallboard** – 2 layers of 12.7 mm thick by 1219 mm wide Type X gypsum wallboard conforming to the requirements of CAN/CSA-A82.27-M91 “Gypsum Board-Building Materials and Products”. Base layer of gypsum wallboard installed with long dimension perpendicular to the resilient channels and end joints of adjacent boards, staggered 2030 mm and located under resilient channels. Screwed to each resilient channel with 32 mm long Type “S” screws, located 38 mm from edge of board or 10 mm from the ends of board, 272 mm from each edge screw, and 300 mm O.C. in the field of the board. Face layer installed with long dimension perpendicular to the resilient channels and end joints of adjacent boards located between resilient channels. End joints staggered at least 609 mm from those of the base layer and 812 mm those of adjacent boards. Joints in the long direction staggered 610 mm from those of the base layer. Attached through base layer to each resilient channel with 41 mm long Type “S” screws, located 38 mm from the board edges, 272 mm from each edge screw, and 300 mm O.C. in the field of the board. Ends of the board attached to the base layer with 38 mm long Type “G” screws, located 38 mm from the board ends, 51 mm from each edge and 109 mm from each edge screw, and 300 mm O.C. in the field of the board.
9. **Wallboard Screws** – Type “S” and Type “G” self-drilling and self-tapping screws, 32 mm, 38 mm and 41 mm long.
10. **Joint System** (not shown) – Paper tape embedded in joint compound over joints and exposed screw heads with edges of compound feathered out.

References:

- [1] Sultan, M.A., Séguin, Y.P. and Leroux, P., *Results of Fire Resistance Tests on Full-Scale Floor Assemblies*, IRC Internal Report No. 764, National Research Council of Canada, Ottawa, Ontario, Canada, 1998.
- [2] Underwriters' Laboratories of Canada, *Standard Methods of Fire Endurance Tests of Building Construction and Materials*, CAN/ULC-S101-89, Scarborough, Ontario, Canada, 1989.
- [3] Warnock, A.C.C. and Birta, J.A., *Summary Report for Consortium on Fire Resistance and Sound Insulation of Floors: Sound Transmission Class and Impact Insulation Class Results*, IRC Internal Report No. 766, National Research Council of Canada, Ottawa, Ontario, Canada, 1998.
- [4] Warnock, A.C.C., *Sound Transmission Estimates for Steel-Framed Floor Assemblies*, Institute for Research in Construction, National Research Council of Canada, Ottawa, Ontario, Canada, January 12, 2000.
- [5] American Society for Testing and Materials, *Standard Test Method for Laboratory Measurement of Airborne Sound Transmission Loss of Building Partitions*, ASTM E90, Philadelphia, Pennsylvania.
- [6] American Society for Testing and Materials, *Classification for Rating Sound Insulation*, ASTM E413, Philadelphia, Pennsylvania.
- [7] American Society for Testing and Materials, *Standard Test Method for Laboratory Measurement of Impact Sound Transmission through Floor-ceiling Assemblies using the Tapping Machine*, ASTM E492, Philadelphia, Pennsylvania.
- [8] American Society for Testing and Materials, *Standard Classification for Determination of Impact Insulation Class*, ASTM E989, Philadelphia, Pennsylvania.
- [9] Canadian Sheet Steel Building Institute, *CSSBI Residential Steel Framing Member Selection Tables*, S13-99, Cambridge, Ontario.